



International
Handball
Federation

IX. Rules of the Game c) Wheelchair Handball Six-a-Side

Edition: 1 July 2026



Table of contents

Foreword	2
Article 1 – Basics	2
Article 2 – Wheelchair Specifications	6
Article 3 – The Game	7

Note: For the sake of simplicity, this rule book generally uses the male form of words with respect to players, officials, referees, and other persons.



Foreword

The IHF Rules of the Game for Wheelchair Handball Six-a-Side basically follow the IHF Rules of the Game for Indoor Handball.

No special rules shall apply despite having mixed teams. However, due to the different capabilities of players, the amendments listed below shall be implemented and will be used for the upcoming IHF Wheelchair Handball events.



Article 1

1. Basics

1.1. The Game

Wheelchair handball six-a-side is played by two teams of six players including one goalkeeper per team. The aim of each team is to score goals and to prevent the other team from scoring.

Wheelchair handball shall be based on the spirit of Fair Play, dedicated for players with physical impairments.

1.2. The Team

A team delegation consists of a maximum of 20 persons including a minimum of 12 players and a maximum of 16 players. A minimum of three female players shall be part of the team. During a match six players including minimum one female player have to be on the court.

1.3. Players

Players have to verify their status during the classification evaluation. All officials have to be aware of the status of the players. For details please refer to the IHF Wheelchair Handball Classification Rules and Regulations.

Players shall be min. 15 years old; a written permission from the parents for players aged 15-18 years shall be presented prior to the tournament.

1.4. Playing Time and Time-Out

Playing Time

Matches will be played with two halves of 20 minutes each. The half-time break will be 10 minutes.

Team Time-Out

Each team shall be granted one 1-minute team time-out in each half of the regular playing time. The team requesting a team time-out must be in the possession of the ball.

If a team requests a team time-out when the opposing team is in possession of the ball, the following punishment and decision will apply:

- a) Progressive punishment starting with a suspension for the team official who requested the team time-out by pushing the buzzer.
- b) 7-metre throw for the team in possession of the ball.

If a team requests a team time-out when the opposing team is in possession of the ball and has a clear chance of scoring, the following punishment and decision will apply:

- a) Disqualification (red and blue card) for the team official that requested the team time-out by pushing the buzzer.
- b) 7-metre throw for the team in possession of the ball.

Note:

If the delegates or the referees do not recognise who has caused a faulty team time-out, the responsible team official will receive the punishment according to the above-mentioned punishments.

If a team requests a team time-out immediately after losing ball possession and it is clear that it was not intentional, the match shall restart according to the technical decision based on the situation on the court at the time of the interruption.

1.5. The Ball

The tournament will be played with size 2 balls following the official IHF dimensions.

1.6. The Court

The entire surface of the court should be at least 48 m long and 28.5 m wide. The playing court is a 40 metres long and 20 metres wide rectangle, consisting of two goal areas and a playing area. The longer boundary lines are called side lines, and the shorter ones are called goal lines (between the goalposts) or outer goal lines (on either side of the goal).

The substitution area should be 4.5 m long. There should be a safety zone surrounding the playing court, with a width of 2 m behind the goal lines. The safety zone along the side lines should be 4 m wide on the side of the substitution area and 1 m on the opposite side.

A max. of four chairs shall be available on every side for the team officials.



1.8. Equipment

The following material is not permitted:

- Glue for handling the ball
- Protective equipment if including metal components
- Finger, hand, wrist, etc. braces made of plastic, metal, etc.

It is permitted to use:

- Gloves (soft, without any support, etc.)
- Protective equipment if padded / soft (not including metal)
- Taping band for fingers, arms, etc.
- Prostheses and adaptive equipment if they are in accordance with Article 4.4.1 of the IHF Wheelchair Handball Classification Rules and Regulations and if the use does not harm any other player.

Comments:

The use of prostheses is permitted only with the approval of the Wheelchair Handball Classification Team.

The prostheses will only be allowed if covered with padded/soft materials (not including metal).

Players who use prostheses to play must use their prostheses during the evaluation by the Wheelchair Handball Classification Team.

However all equipment shall be presented on the occasion of the technical meeting for a final decision. The IHF Regulations on Protective Equipment and Accessories shall be applied, with the exception that all players (not only those acting as goalkeepers) are allowed to wear long pants and no socks are required. However, all players shall wear the same pants (either all shorts or all long pants) in the same colour.

1.9. Playing Kit

Each team shall arrive with 2 playing kits (one light colour / one dark colour). The jerseys shall have the player's number on the front (10 cm in height).

Special protective equipment customized to the players does not need to have the same colour as the dresses.

A colour code will be used to identify the class of each player. The code (=sticker) including the player's number will be placed on the back rest of the wheelchair after the classification.

Class 1 = green	Class 3 = blue
Class 2 = yellow	Class 4 = red

1.10. Straps

Players have to be strapped to the wheelchair at the upper and lower legs in order to avoid lifting or moving/using the legs.

Lifting of field players when playing / defending the ball will be punished with a 2-minute suspension; lifting of the goalkeeper while defending will be punished with a 2-minute suspension and the awarding of a 7m throw.



Article 2

2. Wheelchair Specifications

The wheelchairs shall be constructed in a safe and fair way without any risk for the player himself, his team colleagues or the opposing team. A wheelchair may be banned from the game if there is any concern about its safety or fairness (IHF Supervisors' decision). All wheelchairs used in the tournament will be checked by the officials prior to the tournament. Only verified wheelchairs can be used during the tournament.

Each team is solely responsible for maintenance, etc. of their wheelchairs during the tournament.

The following specifications shall apply:

- No electronic wheelchairs are allowed.
- A horizontal bar shall be placed at the front of the wheelchair (at a height of approx. 11 cm above floor level). However, it is mandatory to use a complete wing covering the front and side of the wheelchair in order to protect the players.
- 1-2 anti-tip devices shall be attached to the wheelchair.
- The maximum height (from the floor to the top of the cushion or seat platform) shall not exceed 63 cm.

- 5-6 wheels (2 large wheels in the rear, two at the front and one or two safety wheels on the back. Max. diameter of large wheels: 71 cm (28 inches)).
- 1 hand rim on each wheel obligatory.
- Both wheels need to be fully covered. When using cover all players of one team shall use the same design.
- In case carbon fibre spokes are used, no cover will be needed.
- Padding of bar at back of the backrest (15 mm).
- If a wheelchair is no longer functional or unsafe, the player has to leave the field for any repairs.

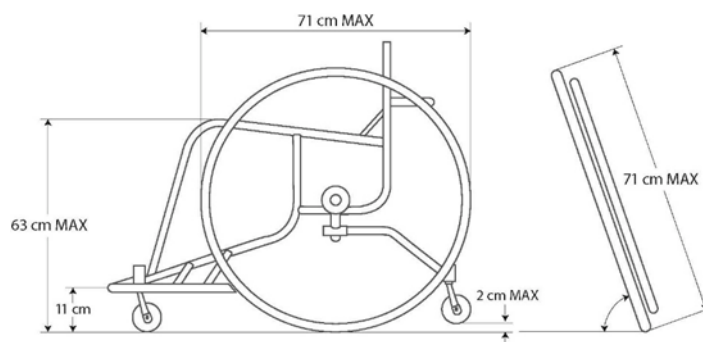

Article 3

3. The Game

3.1. Playing the Ball

It is permitted to:

- throw, catch, stop, push or hit the ball by using hands, arms, head and torso;
- hold the ball for a maximum of 3 seconds;
- push the wheelchair and dribble the ball;
- place the ball on the lap (not between the knees) while pushing the wheelchair for a maximum of 3 seconds;
- monitor and follow the opponent (with or without ball) by using arms and hands as long as the opponent has enough time and distance to react and no danger is present;
- block or force away an opponent with arms or hands, wheelchair (when the player is at a moderate speed);
- enter the goal area or cross the side lines without the ball after a shot or after being pushed when not creating an advantage doing so; the player has to leave the goal area as soon and fast as possible.

It is not permitted to:

- touch the ball more than once, after it has been controlled, unless it has touched the floor,

another player, or the goal in the meantime; however, touching it more than once is not penalised, if the player is “fumbling” the ball, i.e., failing to control it when trying to catch or stop it;

- start bouncing (by the same player) after a throw, before another player or a goalpost touched the ball;
- stop the ball with the wheelchair outside the goal area;
- enter the goal area with the ball under control (as court player);
- cross the side line with the ball under control (the wheelchair has to be in the field).

Comments:

The wheelchair can be pushed for a maximum of 3 seconds; it is allowed to place the ball on the lap during these pushes. A ball on the lap is considered as “under control”. The opponent is therefore not allowed to take the ball off the laps.

After receiving the ball, the player has to start the action by bouncing.

“Pushing” means pushing/moving the wheel. When the hand leaves the wheel the next action (dribbling, passing, shooting) has to follow within 3 seconds. It is not allowed to touch the wheel again after those 3 seconds.

It is not allowed to hold the ball for more than 3 seconds.

In case a ball is thrown against a wheelchair or covered under a wheelchair the referees have to decide on the intention and the respective consequences.

It is allowed to use/touch the wheelchair for picking up the ball.

The new rules regarding goalkeeper, 30 seconds and passive play shall apply.

3.2. Violations

Violations shall be handled according to the IHF Rules of the Game for Indoor Handball:

- Yellow card
- 2-minute suspension
- Disqualification
- Team penalty

It is permitted to:

- use an open hand to play the ball out of the hand of another player;
- use bent arms to make body contact with an opponent, and to monitor and follow him in this way;
- use one's wheelchair to block the opponent, in a struggle for positions.

It is not permitted to:

- pull or hit the ball out of the hands of the opponent;
- block the opponent with arms, hands, legs, wheelchair or to use any part of the body to displace

him or push him away; this includes a dangerous use of the elbow, both as a starting position and in motion;

- hold an opponent (wheelchair, body or uniform), even if he remains free to continue the play;
- endanger an opponent.

Comments:

Blocking an opponent by holding the wheelchair will be punished progressively.

Front contacts are tolerated, but side and rear contacts must be punished. For all these fouls, the chair is considered as part of the player and the non-accidental contact between chairs also constitutes a foul. 7 m shots, free throw, etc. have to be taken from behind the respective lines.

Fouls that warrant a personal punishment

Fouls, where the action is mainly or exclusively aimed at the body of the opponent, must lead to a personal punishment. This means that, in addition to a free throw or 7-metre throw, at least the foul is to be punished progressively, beginning with a warning, then with 2-minute suspensions and disqualification.

Fouls that warrant an immediate 2-minute suspension

For certain fouls, the punishment is a direct 2-minute suspension, regardless of whether the player had received a warning earlier.

This applies especially for such fouls where the culpable player disregards the danger to the opponent. Taking into account the decision-making criteria for fouls that warrant a personal punishment, these fouls may include:

- fouls that are committed with high intensity or against an opponent who is “driving” fast;
- holding on to the opponent for a long time, or pulling him down;
- fouls against the head, throat or neck;
- hard hitting against the torso or throwing arm;
- attempting to make the opponent lose body control;
- driving the wheelchair in great speed into an opponent;
- exceeding the maximum classification team points.

Comments:

In case of a 2-minute suspension / disqualification the maximum classification team points will be reduced by the number of points of the punished player for 2 minutes.

Female players: In case no female player is able to play (due to injuries or punishments) the team concerned will be reduced by one player for the rest of the match. In addition the maximum team points will be reduced to 13. A player announced as injured (leading to the reduction of the team size and team points) is not eligible to play in the respective match again (at a later stage).

Fouls that warrant a disqualification

A player who is attacking an opponent in a way that is dangerous to his health is to be disqualified. The special danger to the opponent's health follows from the high intensity of the foul or from the fact that the opponent is completely unprepared for the foul and therefore cannot protect himself.

During the game, in no case is the athlete allowed to rise from the chair (compulsory use of a belt fixing to the chair) to get an advantage. Fixations can only be opened to enable the player to get back into the wheelchair after a fall.

The disqualification of a player or team official is always for the entire remainder of the playing time. For details please refer to the IHF Rules of the Game for Indoor Handball.

The referees shall use the international hand signals.