



International  
Handball  
Federation

# V. Regulations for IHF Competitions

Edition: 14 January 2018

## Table of contents

1. Basic principles
2. Men's and Women's World Championships
3. Men's Junior (U21) World Championship  
Men's Youth (U19) World Championship  
Women's Junior (U20) World Championship  
Women's Youth (U18) World Championship
4. Olympic Games
5. Olympic Qualification Tournaments
6. Super Globe
7. Equipment Regulations



## ARTICLE 1

---

### I. Basic principles

According to Art. 3 of the IHF Statutes, the International Handball Federation (IHF) shall hold World Championships for men, women, men's juniors (U21), women's juniors (U20), men's youth (U19), women's youth (U18), beach handball and qualifying rounds for World Championships and Olympic Games, World Cups for club teams and national teams. It shall also hold, on behalf of the IOC, the Olympic Handball Tournaments for men and women.

The present regulations govern the rights, duties and responsibilities of all parties participating and involved in the preparation and organization of IHF events and shall apply in connection with all other pertinent regulations.

In case of staging events that are not subject to the present regulations, the IHF COC will propose corresponding regulations to be approved by the IHF Executive Committee.

#### 1.1. General Administrative Information

##### 1.1.1. Duties of the participating teams

Teams participating in World Championships, the IHF Super Globe, Olympic Qualification Tournaments and the Olympic Handball Tournaments agree

- a) to comply with the IHF Statutes and Regulations
- b) to cooperate with the IHF and the organiser and to provide all requested data and information within the given deadline
- c) to respect the principles of fairness and fair play as defined in the IHF Statutes
- d) to comply with all competition-related decisions taken by the IHF Competition Management or any other competent body
- e) to promote handball in its best way and to avoid any inappropriate behaviour that might harm the reputation of handball in any way
- f) to be a role model and to stand for the ideological values of the handball family

Further all participating teams shall respect their event-related tasks such as

- g) announcing the requested data as published in the official announcement or in the present regulations on time (arrival, team photo, etc.)
- h) confirming that all players competing at the tournament fulfil the medical and physical conditions for participation (see 2.10).

In case of non-compliance with these duties penalties and fines may be imposed.

### **1.1.2. Personality rights**

All participating teams grant the IHF (and the IOC, in case of Olympic Handball Tournaments) the right to use photos and graphic materials of players and officials. Further, names and emblems of member federations may be used for event-related purposes.

All participating teams grant the IHF (and the IOC, in case of Olympic Handball Tournaments) the right to use any kind of material produced for or at IHF World Championships, the IHF Super Globe, Olympic Qualification Tournaments and Olympic Handball Tournaments for the promotion of IHF (and IOC, in case of Olympic Handball Tournaments) events and sport development projects.

## **1.2. General Technical Information**

### **1.2.1. Cancellation or discontinuation of match**

If the match is cancelled or discontinued, the Competition Management shall decide on further action.

### **1.2.2. Official balls**

Only balls of the IHF partner will be used at IHF World Championships, the IHF Super Globe, Olympic Qualification Tournaments and the Olympic Handball Tournaments. For all events, except the IHF Super Globe, all participating teams will receive training balls in advance to get familiar with the ball.

### **1.2.3. Playing halls**

IHF competitions shall exclusively be held in playing halls complying with the IHF Regulations and the respective IHF Bid and Event Manual in case of World Championships.

#### **1.2.4. Substitution area**

The IHF Substitution Area Regulations shall apply. No facilities and sport equipment (e.g. bicycles, barbells, etc.) are allowed in the substitution area for the warm-up.

#### **1.2.5. Competition Management**

A Competition Management shall be formed, which is generally chaired by the COC Chairperson. Members are the PRC Chairperson and the CCM Chairperson. In case of absence of certain members the Executive Committee may nominate replacements or the present Technical Delegates as members of the Competition Management, respectively in case of Olympic Handball Tournaments.

The Competition Management is responsible for the orderly management of the event, in close cooperation with the organiser. It represents the first contact point for organisational issues. It gives advice and makes all the necessary decisions during the event, with the exception of disciplinary decisions. It is also responsible for the appointment of Officials, Technical Delegates and referees.

In the venues where the Competition Management is not present the body delegates the aforementioned tasks to the COC delegate (to be announced in IHF INFO), who is supported by a member of the Head Office.

#### **1.2.6. Referees / Technical Delegates / Officials**

The IHF nominees (Representatives, Officials, Delegates, Referees, etc.) are announced at the latest three months prior to the start of the World Championships and the Olympic Handball Tournaments, 2 months prior to the start of Olympic Qualification Tournaments and one month prior to the start of the IHF Super Globe.

#### **1.2.7. Match Management**

One IHF Official and two IHF Technical Delegates shall form the Match Management (Match Jury, in case of Olympic Handball Tournaments) together with the timekeeper and scorekeeper appointed by the organiser. At least one of those two persons shall be fluent in English. The announcer shall be seated near the table.

#### **1.2.8. Match supervision**

The match shall be under the IHF Official's full supervision.

### **1.2.9. Technical Meeting**

A Technical Meeting with the team officials of the participating delegations, the organiser and the IHF representatives shall be held at the beginning of the tournament. In this meeting, all necessary information will be provided and organisational, technical and financial issues can be settled. Furthermore the definitive registration lists will be approved and the uniform colours for the preliminary round will be determined.

Further Technical Meetings might be held if required.

### **1.2.10. Doping tests**

Doping tests shall be carried out according to the IHF Anti-Doping Regulations (and with the guidance of the IOC and in compliance with the World Anti-Doping Code and its relevant International Standards, in the case of Olympic Handball Tournaments).

Doping tests shall be carried out with the guidance of the IOC in accordance with the IOC Anti-Doping-Rules and in compliance with the World Anti-Doping Code and its relevant International Standards.

## **1.3. Legal Section**

Any disputes arising during a competition shall be dealt with by the IHF appeal authorities. The procedure of raising protests and appeals and further specifications are laid down in the Legal Provisions. In addition the IHF will describe the procedures that apply for the relevant event in the corresponding official announcement.





FEDERATION:  
FEDERATION:  
VERBAND:

Provisional Team Registration no later than  
Inscription d'équipe provisoire au plus tard le  
Provisorische Mannschaftsmeldung bis

*Event logo*

**OFFICIALS / OFFICIELS / OFFIZIELLE:**

Name	First Name	Date of Birth	Position	Gender
A.				
B.				
C.				
D.				
E.				
F.				

Colours of Players' Clothing

	Shirt	Short	Goalkeeper
1			
2			
3			

*\*GK=Goalkeeper, LW=Left Wing, RW=Right Wing, LB=Left Back, RB=Right Back, CB=Centre Back, L=Line Player/Pivot*



Annex 2



*Player Replacement Form*

event logo

The Handball Federation of \_\_\_\_\_

changes player

(last name, first name): \_\_\_\_\_

(player number) \_\_\_\_\_

**with**

player

(last name, first name): \_\_\_\_\_

No	Date of Birth	Club	Height	Weight	Main Position	Int. Matches	Goals

\_\_\_\_\_  
Date, Place

\_\_\_\_\_  
Signature

\_\_\_\_\_  
Name of Delegation  
Representative

Confirmed by International Handball Federation.

\_\_\_\_\_  
Date, Place

\_\_\_\_\_  
Signature

\_\_\_\_\_  
Name of IHF Representative



*Late Registration Form*

event logo

The Handball Federation of \_\_\_\_\_

is adding

player

(last name, first name): \_\_\_\_\_

No	Date of Birth	Club	Height	Weight	Main Position	Int. Matches	Goals

\_\_\_\_\_  
Date, Place

\_\_\_\_\_  
Signature

\_\_\_\_\_  
Name of Delegation  
Representative

Confirmed by International Handball Federation.

\_\_\_\_\_  
Date, Place

\_\_\_\_\_  
Signature

\_\_\_\_\_  
Name of IHF Representative

**2.**

**Men's and Women's World**

**Championships**



## ARTICLE 1

---

### I. Awarding

The IHF Council entrusts Men's and Women's World Championships (WCh) to a member federation that has applied to hold it. Further regulations and obligations as part of the bidding procedure are laid down in the IHF Bid and Event Manual which forms the basic principles for the preparation and staging of Men's and Women's World Championships.



## ARTICLE 2

---

### II. Administrative Section

#### 2.1. Announcement

The IHF Head Office shall announce Men's and Women's Championships, with reference to the Statutes and the Regulations for IHF Competitions. This announcement will be sent to the participating federations and will contain, in large parts, information laid down in the Competitions section of the IHF Statutes and Regulations, but also more specific information about the event including all dates and deadlines which shall be respected.

#### 2.2. Number of participants

The number of participants at Men's and Women's World Championships shall be 24 teams. The IHF Council, respectively, shall decide on special cases.

#### 2.3. Compulsory and performance places

The 24 teams participating at the World Championship are composed as follows.

Organiser:	<b>one (1)</b>
Reigning World Champion:	<b>one (1)</b> The reigning World Champion automatically qualifies for the next World Championship.
Performance places for the Continental Confederations:	<b>eight (8)</b> based on the teams ranked 1-8 of the preceding World Championship

Compulsory places (13 in total):	
Africa	<b>three (3)</b>
Asia	<b>three (3)</b>
Europe	<b>three (3)</b>
Pan-America	<b>three (3)</b>
Oceania	<b>• see below</b>
Continent of reigning World Champion:	<b>one (1)</b>

Further definitions regarding compulsory and performance places:

Men's World Championships:

The following conditions apply to receive the compulsory places

- a) At least eight teams must take part in the qualification on the continents in order to receive the three compulsory places.
- b) If the total number of teams is higher than three due to possible performance places, the minimum number of participating teams in the qualification round must be at least twice the number of places.
- c) If this condition is not fulfilled, the number of places is reduced by one.
- d) In this case, the open place is awarded to the continent of the reigning champion

For Women's World Championships, paragraph a) shall be as follows:

- a) At least eight teams must take part in the qualification on the continents in order to receive the three compulsory places. In case of less teams participating, at least twice the number of entitled compulsory places (see above) must take part in the qualification on the continents in order to receive the three compulsory places.

Oceania:

The Continental Confederation of Oceania is not having a direct compulsory place for a Continental Confederation qualification event. The continent of Oceania is invited to take part in the Asian qualification events. The compulsory place is awarded to Oceania if the representative from Oceania is ranked 5<sup>th</sup> or better in the Asian qualification.

In case Oceania is not reaching rank 5 or not participating the IHF Council is awarding this place as a free wild card.

Competitive clause:

To participate in IHF World Championships a certain performance level of the qualified team is obligatory. In case the competitive capability of a qualified team is disputable and the difference in performance level between the country in question and the other teams qualified for the WCh is too large, the IHF Council reserves the right to re-award this place to a country meeting the corresponding competitive requirements in order to strengthen and protect the IHF World Championship product. In such cases an in-depth analysis has to be carried out by the respective IHF Commissions (COC, CCM). Also the current performance as well as the IHF ranking and the performance in earlier IHF events will be taken into consideration when evaluating the performance level of the respective team. Therefore the IHF bodies will issue performance reports about all participating teams immediately after the end of the respective World Championship.

The IHF must analyse such situations within two months after the respective WCh in order to make sure that the number of places for the different Continental Confederations are defined before their qualification process starts.

In case performance or compulsory places are reduced the places are awarded to the continent of the reigning World Champion.

In case the continent of the World Champion is the continent from which the place is reduced, the IHF Council has to award the place to a Continental Confederation.

The 24 teams will be seeded in the performance rows as follows:

1	Reigning World Champion	Performance place 1	Performance place 2	Performance place 3
2	Performance place 4	Performance place 5	Performance place 6	Performance place 7
3	Performance place 8	Organiser	Continent of reigning World Champion	Compulsory place
4	Compulsory place	Compulsory place	Compulsory place	Compulsory place
5	Compulsory place	Compulsory place	Compulsory place	Compulsory place
6	Compulsory place	Compulsory place	Compulsory place	Compulsory place

The teams will be assigned the corresponding places according to the qualifications on continental level. The continental confederation will inform the IHF – based on the performance criteria at their qualification – which place will be allocated to which qualified team.

In the case of a World Championship awarded to two organisers, the place of “Continent of reigning World Champion” will be awarded to the 2<sup>nd</sup> host. In case of more than two organisers, the necessary places will be taken additionally from the compulsory places. All hosting federations are automatically entitled to take part at the World Championship.

As a rule the organiser will be allocated the first place behind the performance places. Should the organiser achieve a better place as a result of the previously staged World Championship, it will be allocated the corresponding performance place. In case the organiser did not reach a better place at the previously staged World Championship, but reached a better position at the continental qualification event, they will be seeded on this performance place.

In case of more than one organiser, the hosting federations will be allocated the places behind the performance places if the above criteria do not apply. The order of the multiple organisers is done based on the result of the preceding World Championships. If this is not possible the IHF COC shall decide the order.

One organiser can decide on choosing group or assigning teams. In the case of more than one organiser the OC has to assign one team per group including themselves.

The reigning World Champion automatically qualifies for the next World Championship and, as a rule, is placed first in the first performance row. In case the reigning World Champion is also hosting the next World Championship, the right of the automatic qualification for the next World Championship will be granted to the second ranked team. In this case this team is placed in the first performance row on position three.

#### **2.4. Qualifying for Men’s and Women’s World Championships**

The IHF owns the rights to World Championships qualifications. As laid down in the IHF Statutes, qualifying shall be through the continents (with the exception of the organiser) according to clearly regulated performance criteria and other necessary regulations defined by the IHF. The IHF-COC confirms the final allocation of qualified teams to the performance rows as announced by the continental confederations based on performance criteria. The draw basically takes place after completion of all continental qualifying rounds. At Men’s and Women’s World Championships the draw must not take place before all the participants being definitively qualified.

## **2.5. Qualifying dates**

As a matter of principle, continental qualifying rounds for Men's and Women's World Championships must be completed no later than 6 months before the start of the World Championships.

The continental confederations shall include their qualifying rounds in the IHF calendar. Continental championships, which are qualifying events for World Championships, and/or the qualification events, should be held during the IHF national team weeks defined in the IHF world calendar. In exceptional cases the IHF Executive Committee may decide about deviations herefrom.

## **2.6. Registration**

Continental Confederations shall give a binding agreement to accept the places open to them at the latest three months after the World Championship where the performances and compulsory places for the next event have been defined. The same applies for the reigning World Champion.

Upon completion of qualifications the continental confederations are obliged to inform the IHF Head Office within one (1) week about the ranking, the teams qualified and the substitute nations.

Teams participating in the qualification events automatically confirm their participation at the respective World Championship in case qualified.

The participants have to pay a deposit and a registration fee to the IHF. Details hereto are laid down in the Financial Section (Article 5). If these deadlines are not met, qualification shall lapse. In such a case, the substitute nation nominated by the Continental Confederation shall be eligible to play.

### **Failure to meet payment dates**

If a federation does not meet the payment dates for an IHF event, additional fines may be imposed. Repeated payment failure can result in the exclusion of the federation from the corresponding IHF event. Specifications and consequences in case of failure to meet payment dates are laid down in the Regulations concerning Penalties and Fines.



## **2.7. Draw**

The draw, held by the IHF (COC), shall be in compliance with the performance criteria. The organiser shall have a free choice of its preliminary round group within its performance row that is drawn last. Alternatively the organiser may submit a request to the IHF to assign one team (including the organiser's team) per city and group. The group assignment to the cities will be done by draw and cannot be changed (Group A / City A, Group B / City B etc.).

In the case of more than one organiser, the performance row of the main organiser (to be defined by the organisers) is drawn last and the main organiser shall have a free choice of its preliminary round group within its performance row. The performance row of the secondary organiser is drawn second to last and the secondary organiser shall have as well free choice of its preliminary round group.

In the case of more than one organiser and the case that organisers are in the same performance row the main organiser shall have a free choice of its preliminary round group first, followed by the choice of the preliminary round group of the secondary organiser.

Technical and organisational details about the draw event are laid down in the IHF Bid and Event Manual.

## **2.8. Non-appearance**

If the team of a federation that has qualified for the World Championship does not take part, the IHF Executive Committee shall decide on a respective substitute nation.

If a Continental Confederation does not use its performance or compulsory places, the IHF Executive Committee shall decide on the reallocation of such places.

## **2.9. Team registration**

Delegations may consist of up to 30 persons. The participating federation must bear the costs of delegation members ranked 22<sup>nd</sup> to 30<sup>th</sup> in the list. These delegation members have the same rights and duties (usage of organised transport, accreditation, meals, etc.) as the first 21 ranked delegation members, in case they have been officially registered by the corresponding national federation and the conditions and requirements outlined by the organiser have been respected. In case the participating federation fails to pay the fixed fee for additional participants, these additional participants are not entitled to use the services included in the rights of participating teams (accommodation, meals, transportation, medical care, etc.), laid down in 2.11. of the present document.

Players and the remainder as officials (stating their function) shall be registered as follows:

- provisionally: one month before the World Championship at the latest (28 players at most) to the organiser as well as the IHF Head Office
- definitively: one hour before the Technical Meeting to the responsible IHF representative (16 players taken from the provisional list and five (5) definitive officials). The registration must be executed with help of the relevant IHF form (see Annex 1).

The registration, on the relevant IHF form, must include:

- a) officials (who should not be changed during the entire competition)\* with the following details: surname, first name, date of birth, nationality, gender, function within the delegation and indication of the officials (by use of letters A, B, C, D,E, F); the following functions must be used: head coach, assistant coach, physiotherapist, doctor, team official  
*\*In exceptional cases the IHF Competition Management may allow the replacement of up to two officials during competition on request of the NF concerned (e.g. in case of serious health issues).*
- b) players with the following details: players' number, surname, first name, club, date of birth, height, weight, throwing hand, main position, number of international games, number of goals scored in international matches
- c) colour of players' uniforms (see Equipment Regulations for detailed specifications)

In case of submitting incorrect or incomplete forms fines may be imposed.

#### Provisional registration

Even if a team has registered less than 28 players, the provisional list is final and cannot be changed once the deadline has expired.

#### Player replacement

During the World Championship each team may replace up to three players (against three players indicated in the provisional list) at any time (e.g. each team may put in three new players or may put in a player who has already been replaced once). Players may be replaced against players indicated in the provisional delegation list ('list of 28') only.

In case a suspended player is replaced by another player, the new player is only eligible to play after the suspension has lapsed.

If a team has registered less than 16 players, it may register one additional player during the World Championship.

*Procedure for late registration or substitution of one or several players:*

New players must be orally registered to the Competition Management or the responsible IHF delegate in the corresponding venue at 9.00 am on the respective matchday at the latest. A written registration and a proof of citizenship (passport, etc.) shall follow one hour before the match at the latest. The official IHF form must be used. (see Annex 2)

**2.10. Formal confirmation of participation**

All qualified federations have to confirm their participation at Men's and Women's World Championships in writing by use of the corresponding form attached to the official announcement. Further the participating nations are held to confirm that all players competing in the tournament fulfil the medical and physical conditions for participation. For that purpose the players to compete in the World Championship shall undergo a medical exam in advance in order to receive a certificate of health. By use of the corresponding form the federations concerned shall confirm the corresponding health status of their players saying that they have received such certificate and fulfil the medical and physical conditions to compete at the World Championship.

**2.11. Rights of participating teams**

All officially registered delegation members will be treated in the same way and have the same rights, including, but not limited to

Accommodation

All teams are accommodated at IHF approved hotels of international level and according to IHF requirements. 8 double and 5 single rooms per team are foreseen (21 persons; 16 players and 5 officials).

Rooms for delegation members 22<sup>nd</sup> – 30<sup>th</sup> are guaranteed provided that the indicated deadline has been respected (see 2.9. team registration). If a team arrives with less than 21 players, it is only entitled to receive the adequate number of rooms according to the size of the delegation.

Food and beverages

Teams have the right to 3 meals a day: breakfast, lunch, and dinner. On matchdays the teams are also entitled to have a snack. One soft drink for lunch and dinner is free; water shall be available 24hrs a day free of charge.

Meeting rooms

At the team hotel all teams have the right to use a meeting room equipped with DVD player, projector and flip chart. A timetable is set up by the Organising Committee in order to reserve

the meeting room for the times preferred. The teams are entitled to use this meeting room free of charge provided they respect the relevant timetable.

#### Team guide

Team guides are at the disposal of each team. They form the link between the participating team concerned, the organiser and the IHF and assist the teams in all matters.

#### Visa

All teams have the right to be guaranteed trouble free entry into the hosting country. Visa assistance shall be provided by the Organising Committee.

#### Local transportation

A heated/air-conditioned bus for local transportation for competition purposes from the day of arrival until the day of departure is available for each team.

#### Medical care

At each venue a comprehensive medical service (including 24-hour emergency) is available for every accredited participant.

#### Accreditation

All delegation members (for specifications refer to 2.9 team registration) shall have access to the field of play, the spectators' area and the media centre.

#### Executive team representative's rights

The head of delegation and one further member (to be defined by the National Federation in advance) will receive further treatments (e.g. access to VIP zones, invitations to official receptions, etc.).

#### World Championship tickets

Each team has the right to buy World Championship tickets. The amount of tickets available per team and the terms and conditions will be published in the official announcement.

#### VIP tickets

Further each participating federation receives a maximum of 2 VIP accreditation cards, including one ticket per accreditation to World Championship matches of its team. The participating federation has to announce the respective persons one month in advance. Unless announced in advance, they are not entitled to the named accreditation/ticket.

### Match DVD

Each team shall receive a match DVD free of charge after every match in which the corresponding team has participated. DVDs of other matches can be purchased at a price of CHF 30.-.

### Video recordings

One person per team and per venue is entitled to make video recordings for teaching and training purposes. Any person wishing to record a match must possess an accreditation card issued by the organiser. These video recordings must not be for commercial exploitation. A special authorization to make video recordings is not required; the Organising Committee however, shall issue the corresponding access authorization.

### Match statistics

Teams have the right to receive the official match statistics of each World Championship match in printed or electronic form.

### Head of delegation conference

The head of each delegation may participate at the head of delegation conference taking place in due time prior to the tournament. A corresponding announcement will be submitted to the participating teams.

## **2.12. Duties of the participating teams**

Teams participating in World Championships agree

- a) to comply with the IHF Statutes and Regulations
- b) to cooperate with the IHF and the organiser and to provide all requested data and information within the given deadline
- c) to respect the principles of fairness and fair play as defined in the IHF Statutes
- d) to comply with all competition-related decisions taken by the IHF Competition Management or any other competent body
- e) to promote handball in its best way and to avoid any inappropriate behaviour that might harm the reputation of handball in any way
- f) to be a role model and to stand for the ideological values of the handball family

Further all participating teams shall respect their event-related tasks such as

- g) announcing the requested data as published in the official announcement or in the present regulations on time (arrival, team photo, etc.)
- h) confirming that all players competing at the tournament fulfil the medical and physical conditions for participation (see 2.10).

In case of non-compliance with these duties penalties and fines may be imposed.

### **2.13. Personality rights**

All participating teams grant the IHF the right to use photos and graphic materials of players and officials. Further, names and emblems of member federations may be used for event-related purposes.

All participating teams grant the IHF the right to use any kind of material produced for or at IHF World Championships for the promotion of IHF events and sport development projects.

### **2.14. IHF INFO**

In addition to the official announcement the IHF INFO brochure will be published prior to the event, which includes more detailed event-related information and the names and contact details of the IHF nominees in every venue.



## **ARTICLE 3**

---

### **III. Technical Section**

#### **3.1. Player eligibility**

The Player Eligibility Code shall apply. Players shall prove their citizenship by presenting a passport, which will be checked by the COC before the start of the World Championship. IHF shall check the eligibility of all players within one week after receiving the provisional lists.

The minimum age of 16 is fixed for the participation at Men's and Women's World Championships, meaning that players eligible to participate have to turn 16 years on the day of his/her first match at the latest.

If a banned player is used, penalties and fines will be imposed. Please refer to the Regulations concerning Penalties and Fines, article 17.

#### **3.2. Competition dates**

The IHF-COC shall fix the exact dates of the competitions with the following periods being set:

Men.	2 <sup>nd</sup> half of January (ending 2 February at the latest)
Women.	28 November – 22 December

Men's and Women's World Championships shall take place in odd years.

The IHF Executive Committee shall finalise and confirm the dates of the tournament before the corresponding announcement being drawn up.

### **3.3. Match scheme**

24 teams – 4 preliminary round groups with 6 teams each

#### **Preliminary Round**

(Groups A, B, C and D) – (60 matches in total)

Matchday 1 1 – 4 2 – 6 3 – 5

Matchday 2 4 – 2 5 – 1 6 – 3

Matchday 3 1 – 6 2 – 3 4 – 5

Matchday 4 2 – 5 3 – 1 6 – 4

Matchday 5 5 – 6 3 – 4 1 – 2

The preliminary round must contain at least 2 rest days.

The top three teams each of preliminary round groups A/B and C/D are put together in groups MRI and MRII of the main round, respectively.

The teams ranked 4<sup>th</sup> to 6<sup>th</sup> in preliminary round groups A, B, C and D will compete in the President's Cup.

#### **President's Cup**

**Determination of places 13–16 (4 matches in total)**

4.A – 4.B, 4.C – 4. D

*The winners compete for places 13/14; the losers compete for places 15/16.*

**Determination of places 17– 20 (4 matches in total)**

5.A – 5.B, 5.C – 5. D

*The winners compete for places 17/18; the losers compete for places 19/20.*

**Determination of places 21–24 (4 matches in total)**

6.A – 6.B, 6.C – 6. D

*The winners compete for places 21/22; the losers compete for places 23/24.*

In case of a draw at the end of the regular playing time direct 7m penalty throws shall be used to decide a winner in accordance with Rule 2.2 of the Rules of the Game for all matches in the President's Cup.

## Main Round

The top three teams each of preliminary round groups A/B and C/D are put together in groups MRI and MRII of the main round, respectively. The results of the teams having played in the same preliminary round group are taken into consideration.

Group Main Round I	Group Main Round II
1. A    2. A	1. C    2. C
3. A    1. B	3. C    1. D
2. B    3. B	2. D    3. D

Group	Main Round I	Main Round II
Matchday 1	2.A-3.B / 3.A-1.B / 1.A-2.B	2.C-3.D / 3.C-1.D / 1.C-2.D
Matchday 2	1.B-2.A / 3.B-1.A / 2.B-3.A	1.D-2.C / 3.D-1.C / 2.D-3.C
Matchday 3	3.A-3.B / 2.A-2.B / 1.A-1.B	3.C-3.D / 2.C-2.D / 1.C-1.D

## Determination of places 9–12

The teams ranked 5<sup>th</sup> in main round groups I and II will be ranked in 9<sup>th</sup> and 10<sup>th</sup> places; the teams ranked 6<sup>th</sup> will be ranked in 11<sup>th</sup> and 12<sup>th</sup> places. Determination of these places is done by calculation according to the following evaluation criteria.

- a) Number of points gained
- b) In case of equal number of points the goal difference in the preliminary round shall decide.
- c) In case of equal number of points and the same goal difference the larger number of plus goals in the preliminary round shall decide.
- d) If classification is not possible according to points a–c, decision shall be made by drawing lots.

## Determination of places 5–8 (2 matches in total)

4. MRI – 4. MRII (Place 7/8)
3. MRI – 3. MRII (Place 5/6)

The placement matches (5<sup>th</sup>/6<sup>th</sup>) and (7<sup>th</sup>/8<sup>th</sup>) will be played only in years prior to the Olympic Games or on request of the Organising Committee.

## Semi-Finals (2 matches in total)

1. MRI – 2. MRII / SF1
1. MRII – 2. MRI / SF2

*The winners advance to the final; the losers compete for places 3/4.*



## Finals (2 matches in total)

W SF 1 – W SF 2

L SF 1 – L SF 2

### Day by Day •

0- Arrival of all teams	
1- Preliminary Round	(12 matches)
2- Preliminary Round	(12 matches)
3- Rest day	
4- Preliminary Round	(12 matches)
5- Preliminary Round	(12 matches)
6- Rest day	
7- Preliminary Round	(12 matches)
8- Rest day	
9- Main Round / President's Cup	(12 matches)
10- Main Round / President's Cup	(12 matches)
11- Rest day / Departure President's Cup	
12- Main Round	(6 matches)
13- Rest day / Departure 9-12	(2 matches)
14- Semi-Finals / Placement Matches 5/6, 7/8	(4 matches)
15- Rest day	
16- Finals	(2 matches)
17- Departure	

*\*This is a general set-up. On request of media, TV or other international bodies, the IHF-COC may decide an alternative schedule, following the above-mentioned principles. Different rest days in the respective groups may be determined and placement round matches could be adapted to different days. The bronze medal match could be played on day 15. An opening match could be held on day 0.*

### Throw-off times

The throw-off times shall be fixed by the IHF in conjunction with the organiser and the TV rights-holder. Every team must be allocated a break of at least 20 hours between the throw-off times of one match and another.

## **3.4. Match evaluation and determination of places**

### **3.4.1. Preliminary round**

The preliminary round is played in groups. The matches shall be evaluated as follows:

- each match won = 2 points
- each match drawn = 1 point for each team
- each match lost = no points

Teams are ranked according to the total number of points gained.

If two or more teams have gained the same number of points after the group matches have been completed, classification is decided as follows:

- results in points between the teams concerned
- goal differences in the matches between the teams concerned
- greater number of plus goals in the matches between the teams concerned.

If the teams are still equal, a decision is made between those teams with equal number of points as follows:

- goal difference is subtracted in all matches
- greater number of plus goals in all matches.

If classification still is not possible, a draw shall decide. The IHF representative on site shall execute the draw, if possible in the presence of the ‘responsible team officials’. If the ‘responsible team official’ cannot be present, other co-workers selected by the IHF shall take part.

#### **3.4.2. Placement matches, eighth-finals, quarter-finals, semi-finals and finals**

After completion of the preliminary round, the placement matches, eighth-finals, quarter-finals, semi-finals and finals shall be played in accordance with the knock-out system.

Overtime is played, following a 5-minute break, if a game is tied at the end of the regular playing time and a winner has to be determined. The overtime period consists of 2 halves of 5 minutes, with a 1-minute half-time break.

If the game is again tied after a first overtime period, a second period is played after a 5-minute break. This overtime period also has 2 halves of 5 minutes, with a 1-minute half-time break.

Should the match still not be decided after the second overtime period, it is decided with 7m penalty throws in accordance with Rule 2.2 of the Rules of the Game.

The IHF COC has the right to decide that certain matches will be executed with direct 7m penalty throws in accordance with Rule 2.2 of the Rules of the Game. If this rule applies, the decision will be published in the official announcement or together with the match schedule.

### **3.5. Cancellation or discontinuation of match**

If the match is cancelled or discontinued, the Competition Management shall decide on further action.

### **3.6. Official balls**

Only balls of the IHF partner will be used at IHF World Championships. All participating teams will receive training balls in advance to get familiar with the ball.

### **3.7. Players' uniform**

Only players' uniforms in accordance with the IHF Equipment Regulations are allowed. The approval procedure must be followed as laid down in the Equipment Regulations. Detailed specifications for players' uniforms including advertising rights and duties are laid down in the Equipment Regulations.

#### *Implementing rules*

At the Technical Meeting held prior to the start of the World Championship each delegation is obliged to show the three differently coloured sets of uniform.

In each match one team shall wear light-coloured shirts and the other team dark-coloured shirts.

For the preliminary round the colours have to be decided at the Technical Meeting before the matches. The decision of colours in each match will be taken with participation of the team representatives and the IHF Technical Delegates. In case of disagreement regarding the colours the team named first has the right to choose the colour.

The Competition Management decides the colours of the players' uniforms for all matches except for the preliminary round matches.

#### **3.7.1. Officials' clothing (team officials A-F)**

Specifications about the clothing of team officials are laid down in the Equipment Regulations.

#### **3.7.2. Referees' clothing**

Specifications about the clothing of referees are laid down in the Equipment Regulations.

### **3.8. Playing halls**

IHF competitions shall exclusively be held in playing halls complying with the IHF Regulations and the respective IHF Bid and Event Manual.

### **3.9. Training sessions**

Two months before the start of the World Championship the training schedule, which has been submitted by the organiser and approved by the IHF, is announced to the teams. The following specifications must be strictly adhered to.

- a) Each team must be granted the same conditions and has the right to train for at least 45 minutes every day. Furthermore all teams shall be entitled to at least one training session in the playing hall prior to its first match in the respective venue. In case training in the playing hall is not possible for extraordinary reasons, the IHF Competition Management may decide.
- b) The break between the training sessions of different teams should be 5 to 10 minutes.
- c) Training sessions may be used for training matches against other teams.
- d) The first 10 minutes of every training session in the respective main hall shall be open to the media. The teams are free to agree on complete training slots open to the media after consultation with the media representatives.
- e) Water for players will be provided during the training session. Further specifications are laid down in the IHF Bid and Event Manual (40. Training schedule).
- f) Each team must bring its own balls to the training hall. For this purpose the competition balls provided to the teams prior to the tournament and supplied by the IHF partner might be used.
- g) The Competition Management has the final decision on the training schedule.

### **3.10. Substitution area**

The IHF Substitution Area Regulations shall apply. No facilities and sport equipment (e.g. bicycles, barbells, etc.) are allowed in the substitution area for the warm-up.

### **3.11. Competition Management**

A Competition Management shall be formed, which is generally chaired by the COC Chairperson. Members are the PRC Chairperson and the CCM Chairperson. In case of absence of certain members the Executive Committee may nominate replacements.

The Competition Management is responsible for the orderly management of the event, in close cooperation with the organiser. It represents the first contact point for organisational issues. It gives advice and makes all the necessary decisions during the event, with the exception of

disciplinary decisions. It is also responsible for the appointment of Officials, Technical Delegates and referees.

In the venues where the Competition Management is not present the body delegates the aforementioned tasks to the COC delegate (to be announced in IHF INFO, see 2.14.), who is supported by a member of the Head Office.

### **3.12. Referees / Technical Delegates / Officials**

The IHF nominees (Representatives, Officials, Delegates, Referees, etc.) are announced at the latest three months prior to the start of the World Championship.

### **3.13. Rules of the Game**

Matches shall be played according to the Rules of the Game currently valid. The IHF has the right to approve special rules valid for World Championships.

In general the following regulations are valid for IHF events:

#### *16 players per match*

16 players may be put in per match at World Championships and related qualifying rounds.

#### *Half-time break*

The half-time break at the World Championship shall be 15 minutes.

#### *Team-Time Out*

According to Rule 2:10 and Clarification 3 of the Rules of the Game each team has the right to receive a maximum of three team time-outs during regular playing time but not during overtime. No more than two team time-outs may be granted in each half of the regular playing time. Between two team time-outs of a team, the opponent must be at least once in possession of the ball. 3 green cards, bearing numbers 1, 2, and 3 respectively, are available for each team. The teams receive cards bearing numbers '1' and '2' in the first half of the game and the cards no. 2 and no. 3 in the second half provided they received no more than one team time-out in the first half. In case they received two team time-outs in the first half, they receive only green card no. 3.

Within the last 5 minutes of the regular playing time only one team time-out per team is allowed.

### **3.14. Match Management**

One IHF Official and two IHF Technical Delegates shall form the Match Management together with the timekeeper and scorekeeper appointed by the organiser. At least one of those two persons shall be fluent in English. The announcer shall be seated near the table.

### **3.15. Match supervision**

The match shall be under the IHF Official's full supervision.

### **3.16. Technical Meeting**

A Technical Meeting with the team officials of the participating delegations, the organiser and the IHF representatives shall be held at the beginning of the tournament. In this meeting, all necessary information will be provided and organisational, technical and financial issues can be settled. Furthermore the definitive registration lists will be approved and the uniform colours for the preliminary round will be determined.

Further Technical Meetings might be held if required.

### **3.17. Doping tests**

Doping tests shall be carried out according to the IHF Anti-Doping Regulations.

### **3.18. Scouting system**

The IHF and the organiser assure the data processing to produce all match-relevant statistics.

### **3.19. Prize money**

The teams ranked first to third will receive prize money. Details hereto are specified in the corresponding official announcement.



## **ARTICLE 4**

---

### **IV. Legal Section**

Any disputes arising during a competition shall be dealt with by the IHF appeal authorities. The procedure of raising protests and appeals and further specifications are laid down in the Legal Provisions. In addition the IHF will describe the procedures that apply for the relevant event in the corresponding official announcement.



## V. Financial Section

The participants shall bear the following costs:

### Travel expenses

Travel expenses for the entire participating delegation have to be borne by the participating national federations, unless otherwise decided and communicated by the IHF. The IHF shall fix the place of arrival and departure in close cooperation with the organiser.

### Costs of visas

Participants shall bear all costs in connection with obtaining necessary visas.

### Registration fee

Nations taking part in the World Championship tournament shall pay the IHF a registration fee of CHF 1,000.–. The payment deadline is the same date as the registration deadline.

### Fixed deposit

All participants shall pay the IHF, at the same time as the registration fee, a deposit of CHF 10,000.– which will be taken on account or repaid. If a registering federation has the uncharged sum of CHF 10,000.– on its account with the IHF, this may be used as the fixed deposit. The federation's IHF account will be credited with the relevant sum after the World Championship. If the country withdraws, the sum shall be forfeited to the benefit of the IHF. During the World Championship the IHF has the right to freely dispose of the fixed deposit of each team and may use it to pay fees, fines or other financial obligations of the corresponding federation.

### Expenses in the host country

All expenses arising within the host country in connection with the games have to be borne by the participating teams.

### Accident and sickness insurance

Federations taking part in World Championships are obliged to insure all delegation members, i. e. all players and all officials, against accident and sickness, at their own cost. The organiser and the IHF shall not be held liable for any accidents that occur or any sickness unless the IHF has concluded a corresponding insurance for World Championship participants.

### Days of stay

When calculating the participation fee, the number of days is generally counted from 12 noon on the day of arrival to 12 noon on the day of departure, i.e. although the days of arrival and departure make up two calendar days, they represent only one fee-paying day. (Additional meals – on the day of arrival possibly breakfast, on the day of departure possibly lunch and/or supper – shall be paid for in addition.) Arrival day is generally one day prior to the first match and departure day one day after the last match of the corresponding team.

### Additional days of stay (during the World Championship period)

Participating teams may, with the organiser's agreement, arrive earlier or leave later, but they must bear the additional costs themselves. The exact amount for additional days will be fixed by the organiser and will then be published in the official announcement.

### Extra days (outside the World Championship period)

After coordination with the organiser each team may arrive earlier or leave later provided it pays additional costs set by the organiser and announced by the IHF in the official announcement itself. The exact amount for additional days will be fixed by the organiser and will then be published in the official announcement.

### Additional participants

A team delegation may be composed of 30 persons maximum during the World Championship period provided it pays itself the costs which have been set by the organiser and announced by the IHF in the official announcement (see 2.9.). The exact amount for additional participants is fixed by the organiser and will then be published in the official announcement.

### World Championship Solidarity Fund

Participants will make the following contributions to the World Championship Solidarity Fund.

Men:	10.– CHF per matchday and person (for 16 persons)
Women:	5.– CHF per matchday and person (for 16 persons)

The Executive Committee shall administer the Fund whose purpose is to support national junior and youth teams and enable them to participate in World Championships.





## ARTICLE 6

---

### **VI. Television, media and advertising**

Television, film and video rights, advertising at the playing halls

The IHF alone shall hold these rights. The corresponding agreements shall be made with the respective organiser.

The IHF shall receive the revenues from television, film and video and income from advertising at the halls.

Advertising on sportswear

Rights in respect of advertising on sportswear are laid down in the Regulations on Advertising and the Equipment Regulations.

Video recordings

After the end of the World Championship tournament the organiser shall provide the IHF with video recordings of all matches free of charge.

Press conference

A post-match press conference will take place in general approximately 15 minutes after the end of each match in the press conference room. The head coach and a player of each team shall attend the press conference conducted in English. The IHF Media Department will inform about special requirements on site.



## ARTICLE 7

---

### **VII. Awards and ceremonies**

Pre- and post-match procedure

The procedure before and after the match will be published in the official announcement. All parties involved shall strictly adhere to these guidelines.

Opening and closing ceremony

The opening and closing ceremonies shall be of reasonable and appropriate proportions. Details are contained in the List of Duties for Official IHF Competitions and the IHF Bid and Event Manual.

Winners (places 1 – 3)

Medals and certificates shall be awarded to the three top teams as follows.

- 1<sup>st</sup> place and World Champion (gold)
- 2<sup>nd</sup> place (silver)
- 3<sup>rd</sup> place (bronze)

On the podium a total of 21 persons are allowed (players who have participated in the World Championship and team officials A-E).

All other players and officials of the teams ranked 1 – 3 shall also receive the corresponding medals up to a maximum number of 25 medals.

All other teams shall receive a souvenir medal.

Head Office

One set of medals and certificates shall be preserved in the IHF Head Office archives.

At Men's and Women's World Championships, the following official awards shall be presented:

**a) Player of the Match**

The IHF has the right to award the most valuable player in every World Championship match who shall receive the Player of the Match award. The IHF-CCM (or its representatives) shall decide about the awarding of the player.

**b) All-Star Team**

The IHF All-Star Team will be designated by the IHF-CCM experts attending the World Championship and will be announced after the final.

**c) Top Scorer**

The player who has scored the largest number of goals during the entire World Championship tournament shall receive the IHF Top Scorer award. If two or more players have scored the same number of goals, the number of assists will be decisive.

**d) Most Valuable Player (MVP)**

The best player of the tournament shall receive the MVP award. The MVP will be designated by the IHF-CCM experts attending the World Championship.

No other awards than the aforementioned shall be presented at the World Championship.



**ARTICLE 8**

---

**VIII. Closing comment**

Further provisions regarding organisation are stipulated in the IHF Bid and Event Manual. Should any problems arise at Men's and Women's World Championships that are not covered by the present Regulations, the Competition Management shall decide. In case of non-observance of these Regulations, Regulations concerning Penalties and Fines (XIX.) shall apply.

**3.**

**Men's Junior (U21) World Championship**

**Men's Youth (U19) World Championship**

**Women's Junior (U20) World Championship**

**Women's Youth (U18) World Championship**

*Note. In the present document the term ‘World Championships’ refers to the World Championships of all younger age categories, unless otherwise specified.*



## ARTICLE 1

---

### **I. Awarding**

The IHF Congress entrusts World Championships (WCh) to a member federation that has applied to hold it. Further regulations and obligations as part of the bidding procedure are laid down in the IHF Bid and Event Manual which forms the basic principles for the preparation and staging of IHF World Championships.



## ARTICLE 2

---

### **II. Administrative Section**

#### **2.1. Announcement**

The IHF Head Office shall announce forthcoming IHF competitions, with reference to the Statutes and the Regulations for IHF Competitions. This announcement will be sent to the participating federations and will contain, in large parts, information laid down in the Competitions section of the IHF Statutes and Regulations, but also more specific information about the event including all dates and deadlines which shall be respected.

#### **2.2. Number of participants**

The number of participants at World Championships shall be 24 teams. The IHF Council, respectively, shall decide on special cases.

#### **2.3. Compulsory and performance places**

The distribution of the performance and compulsory places is in general done in accordance with the result of the preceding World Championship. The overview of the seeding will be done by the COC and announced one month after the respective World Championship.

##### **2.3.1. Women's Youth (U18) World Championships**

The 24 teams participating in Women's Youth (U18) World Championships are composed as follows:

Organiser:	<b>one (1)</b>
Performance places for the continental confederations:	<b>eight (8)</b> based on the teams ranked 1–8 of the preceding World Championship.
Compulsory places:	
Africa	<b>three (3)</b>
Asia	<b>three (3)</b>
Europe	<b>three (3)</b>
South and Central America	<b>three (3)</b>
North America and the Caribbean	<b>one (1)</b>
Oceania	<b>one (1)</b>
Continent of reigning Women’s Youth (U18) World Champion	<b>one (1)</b>

The 24 teams will be seeded in the performance rows as follows:

1	Performance place 1	Performance place 2	Performance place 3	Performance place 4
2	Performance place 5	Performance place 6	Performance place 7	Performance place 8
3	Organiser	Continent of reigning Women’s Youth (U18) World Champion	Compulsory place	Compulsory place
4	Compulsory place	Compulsory place	Compulsory place	Compulsory place
5	Compulsory place	Compulsory place	Compulsory place	Compulsory place
6	Compulsory place	Compulsory place	Compulsory place	Compulsory place

The teams will be assigned to the corresponding places according to the qualifications on continental level. The continental confederation will inform the IHF – based on the performance criteria at their qualification – which place will be allocated to which qualified team.

In the case of a World Championship awarded to several organisers the COC Commission will propose adapted performance rows to the IHF Executive Committee for confirmation. All hosting federations are automatically entitled to take part at the World Championship.

As a rule the organiser will be allocated the first place behind the performance places. Should the organiser achieve a better place as a result of the previously staged World Championship qualifications, it will be allocated the corresponding performance place.

The reigning Women’s Youth (U18) World Champion automatically qualifies for the next Women’s Junior (U20) World Championship.

### 2.3.2. Women’s Junior (U20) World Championships

The 24 teams participating at Women’s Junior World Championships (U20) are composed as follows:

Organiser:	<b>one (1)</b>
Performance places for the continental confederations:	<b>eight (8)</b> based on the teams ranked 1–8 of the preceding World Championship.
Compulsory places:	
Africa	<b>three (3)</b>
Asia	<b>three (3)</b>
Europe	<b>three (3)</b>
South and Central America	<b>three (3)</b>
North America and the Caribbean	<b>one (1)</b>
Oceania	<b>one (1)</b>
Winner of IHF Trophy	<b>one (1)</b>

The 24 teams will be seeded in the performance rows as follows:

1	Performance place 1	Performance place 2	Performance place 3	Performance place 4
2	Performance place 5	Performance place 6	Performance place 7	Performance place 8
3	Organiser	Compulsory place	Compulsory place	Compulsory place
4	Compulsory place	Compulsory place	Compulsory place	Compulsory place
5	Compulsory place	Compulsory place	Compulsory place	Compulsory place
6	Compulsory place	Compulsory place	Compulsory place	Winner of IHF Trophy

The teams will be assigned the corresponding places according to the qualifications on continental level. The continental confederation will inform the IHF – based on the performance criteria at their qualification – which place will be allocated to which qualified team.

In the case of a World Championship awarded to several organisers the COC Commission will propose adapted performance rows to the IHF Executive Committee for confirmation. All hosting federations are automatically entitled to take part at the World Championship.

As a rule the organiser will be allocated the first place behind the performance places. Should the organiser achieve a better place as a result of the previously staged World Championship qualifications, it will be allocated the corresponding performance place.

### **2.3.3. Men's Youth (U19) World Championships**

The 24 teams participating in Men's Youth (U19) World Championships are composed as follows:



Organiser:	<b>one (1)</b>
Performance places for the continental confederations:	<b>eight (8)</b> based on the teams ranked 1–8 of the preceding World Championship.
Compulsory places:	
Africa	<b>three (3)</b>
Asia	<b>three (3)</b>
Europe	<b>three (3)</b>
South and Central America	<b>three (3)</b>
North America and the Caribbean	<b>one (1)</b>
Oceania	<b>one (1)</b>
Continent of reigning Men's Youth (U19) World Champion	<b>one (1)</b>

The 24 teams will be seeded in the performance rows as follows:

1	Performance place 1	Performance place 2	Performance place 3	Performance place 4
2	Performance place 5	Performance place 6	Performance place 7	Performance place 8
3	Organiser	Continent of reigning Men's Youth (U19) World Champion	Compulsory place	Compulsory place
4	Compulsory place	Compulsory place	Compulsory place	Compulsory place
5	Compulsory place	Compulsory place	Compulsory place	Compulsory place
6	Compulsory place	Compulsory place	Compulsory place	Compulsory place

The teams will be assigned the corresponding places according to the qualifications on continental level. The continental confederation will inform the IHF – based on the performance criteria at their qualification – which place will be allocated to which qualified team.

In the case of a World Championship awarded to several organisers the COC Commission will propose adapted performance rows to the IHF Executive Committee for confirmation. All hosting federations are automatically entitled to take part at the World Championship.

As a rule the organiser will be allocated the first place behind the performance places. Should the organiser achieve a better place as a result of the previously staged World Championship qualifications, it will be allocated the corresponding performance place.

The reigning Men's Youth (U19) World Champion automatically qualifies for the next Men's Junior (U21) World Championship.

#### **2.3.4. Men's Junior (U21) World Championships**

The 24 teams participating in Men's Junior World Championships (U21) are composed as follows:

Organiser:	<b>one (1)</b>
Performance places for the continental confederations:	<b>eight (8)</b> based on the teams ranked 1–8 of the preceding World Championship.
Compulsory places:	
Africa	<b>three (3)</b>
Asia	<b>three (3)</b>
Europe	<b>three (3)</b>
South and Central America	<b>three (3)</b>
North America and the Caribbean	<b>one (1)</b>
Oceania	<b>one (1)</b>
Winner of IHF Trophy	<b>one (1)</b>

The 24 teams will be seeded in the performance rows as follows:

1	Performance place 1	Performance place 2	Performance place 3	Performance place 4
2	Performance place 5	Performance place 6	Performance place 7	Performance place 8
3	Organiser	Compulsory place	Compulsory place	Compulsory place
4	Compulsory place	Compulsory place	Compulsory place	Compulsory place
5	Compulsory place	Compulsory place	Compulsory place	Compulsory place
6	Compulsory place	Compulsory place	Compulsory place	Winner of IHF Trophy

The teams will be assigned the corresponding places according to the qualifications on continental level. The continental confederation will inform the IHF – based on the performance criteria at their qualification – which place will be allocated to which qualified team.

In the case of a World Championship awarded to several organisers the COC Commission will propose adapted performance rows to the IHF Executive Committee for confirmation. All hosting federations are automatically entitled to take part at the World Championship.

As a rule the organiser will be allocated the first place behind the performance places. Should the organiser achieve a better place as a result of the previously staged World Championship qualifications, it will be allocated the corresponding performance place.

### **2.3.5. Further definitions regarding compulsory and performance places at youth and junior competitions**

The following conditions apply to receive the compulsory places

- a) At least eight teams must take part in the qualification on the continents in order to receive the three compulsory places. In case of less teams participating, at least twice the number of entitled compulsory places (see above) must take part in the qualification on the continents in order to receive the three compulsory places. In Continental Confederations with one compulsory place, at least three teams must take part in the qualification process in order to receive the compulsory place.

- b) If the total number of teams is higher than three due to possible performance places, the minimum number of participating teams in the qualification round must be at least twice the number of places.
- c) If this condition is not fulfilled, the number of places is reduced by one.
- d) In this case, the open place is awarded to the continent of the reigning champion.

#### **2.4. World Championship Qualification**

The IHF owns the rights to World Championship qualifications. As laid down in the IHF Statutes, qualifying shall be through the continents (with the exception of the organiser) according to clearly regulated performance criteria and other necessary regulations defined by the IHF. The IHF-COC confirms the final allocation of qualified teams to the performance rows as announced by the continental confederations based on performance criteria. The draw basically takes place after completion of all continental qualifying rounds. At IHF World Championships the draw must not take place before all the participants being definitively qualified.

#### **2.5. Qualifying dates**

As a matter of principle, continental qualifying rounds must be completed no later than 3 months before the start of the World Championship. The continental confederations shall include their qualifying rounds in the IHF calendar.

#### **2.6. Registration**

Continental confederations shall give a binding agreement to accept the places open to them at the latest three months after the World Championship where the performance and compulsory places for the next event have been defined. The same applies for the reigning Women's Youth (U18)/Men's Youth (U19) World Champion who must give a binding agreement to accept the qualification to the Women's Junior (U20)/Men's Junior (U21) World Championship.

Upon completion of qualifications the continental confederations are obliged to inform the IHF Head Office within one (1) week about the ranking, the teams qualified and the substitute nations.

Teams participating in the qualification events automatically confirm their participation at the respective World Championship in case qualified.

The participants have to pay a deposit and a registration fee to the IHF. Details hereto are laid down in the Financial Section (Article 5). If these deadlines are not met, qualification shall

lapse. In such a case, the substitute nation nominated by the continental confederation shall be eligible to play.

#### Failure to meet payment dates

If a federation does not meet the payment dates for an IHF event, additional fines may be imposed. Repeated payment failure can result in the exclusion of the federation from the corresponding IHF event. Specifications and consequences in case of failure to meet payment dates are laid down in the Regulations concerning Penalties and Fines.

### **2.7. Draw**

The draw, held by the IHF (COC), shall be in compliance with the performance criteria. The organiser shall have a free choice of its preliminary round group within its performance row that is drawn last. Alternatively the organiser may submit a request to the IHF to assign one team (including the organiser's team) per city and group. The group assignment to the cities has to be done before the draw and cannot be changed (Group A / City A, Group B / City B etc.)

In the case of more than one organiser, the performance row of the main organiser is drawn last and the main organiser shall have a free choice of its preliminary round group within its performance row. The performance row of the secondary organiser is drawn second to last and the secondary organiser shall have as well free choice of its preliminary round group.

In the case of more than one organiser and the case that organisers are in the same performance row the main organiser shall have a free choice of its preliminary round group first, followed by the choice of the preliminary round group of the secondary organiser.

Technical and organisational details about the draw event are laid down in the IHF Bid and Event Manual.

### **2.8. Non-appearance**

If the team of a federation that has qualified for the World Championship does not take part, the first substitute nation of the continent in question shall take that place. If the first substitute nation does not take part, the second substitute nation shall take the place.

If this team also does not take part, the place will be allocated to the continental confederation of the reigning World Champion, which will then announce the substitute nation. If the first substitute nation does not take part, the second substitute nation shall take the place. If this team also does not take part, the IHF Executive Committee shall decide.

## 2.9. Team registration

Delegations may consist of up to 30 persons. The participating federation must bear the costs of delegation members ranked 22<sup>nd</sup> to 30<sup>th</sup> in the list. These delegation members have the same rights and duties (usage of organized transport, accreditation, meals, etc.) as the first 21 ranked delegation members, in case they have been officially registered by the corresponding national federation and the conditions and requirements outlined by the organiser have been respected. In case the participating federation fails to pay the fixed fee for additional participants, these additional participants are not entitled to use the services included in the rights of participating teams (accommodation, meals, transportation, medical care, etc.), laid down in 2.11. of the present document.

Players and the remainder as officials (stating their function) shall be registered as follows:

- provisionally: one month before the World Championship at the latest (28 players at most) to the organiser as well as the IHF Head Office
- definitively: one hour before the Technical Meeting to the responsible IHF representative (16 players taken from the provisional list and five (5) officials). The registration must be executed with help of the relevant IHF form (see Annex 1).

The registration, on the relevant IHF form, must include:

- a) officials (who should not be changed during the entire competition)\* with the following details: surname, first name, date of birth, nationality, gender, function within the delegation and indication of the officials (by use of letters A, B, C, D, E, F); the following functions must be used: head coach, assistant coach, physiotherapist, doctor, team official  
*\*In exceptional cases the IHF Competition Management may allow the replacement of up to two officials during competition on request of the NF concerned (e.g. in case of serious health issues).*
- b) players with the following details: players' number, surname, first name, club, date of birth, height, weight, throwing hand, main position, number of international games, number of goals scored in international matches
- c) colour of players' uniforms (see Equipment Regulations for detailed specifications)

In case of submitting incorrect or incomplete forms fines may be imposed.

Provisional registration

Even if a team registers less than 28 players, the provisional list is final and cannot be changed once the deadline has expired.

#### Player replacement

During the World Championship each team may replace up to three players (against three players indicated in the provisional list) at any time (e.g. each team may put in three new players or may put in a player who has already been replaced once). Players may be replaced against players indicated in the provisional delegation list ('list of 28') only.

In case a suspended player is replaced by another player, the new player is only eligible to play after the suspension has lapsed.

If a team has registered less than 16 players, it may register one additional player during the World Championship.

#### *Procedure for late registration or substitution of one or several players:*

New players must be orally registered to the Competition Management or the responsible IHF delegate in the corresponding venue at 9.00 am on the respective matchday at the latest. A written registration and a proof of citizenship (passport, etc.) shall follow one hour before the match at the latest. The official IHF form must be used. (see Annex 2)

### **2.10. Formal confirmation of participation**

All qualified federations have to confirm their participation in writing by use of the corresponding form attached to the official announcement. Further the participating nations are held to confirm that all players competing in the tournament fulfil the medical and physical conditions for participation. For that purpose the players to compete in the World Championship shall undergo a medical exam in advance in order to receive a certificate of health. By use of the corresponding form the federations concerned shall confirm its players' health status saying that they have received such certificate and fulfil the medical and physical conditions to compete at the World Championship.

### **2.11. Rights of participating teams**

Provided that all conditions (e.g. payments) have been met, all officially registered delegation members will be treated in the same way and have the same rights, including, but not limited to

#### Accommodation

All teams are accommodated at IHF approved hotels of international level and according to IHF requirements. 8 double and 5 single rooms per team are foreseen (21 persons; 16 players and 5 officials).

Rooms for delegation members 22<sup>nd</sup> – 30<sup>th</sup> are guaranteed provided that the indicated deadline has been respected (see 2.9.).

If a team arrives with less than 21 players, it is only entitled to receive the adequate number of rooms according to the size of the delegation.

#### Food and beverages

Teams have the right to 3 meals a day: breakfast, lunch, and dinner. On matchdays the teams are also entitled to have a snack. One soft drink for lunch and dinner is free; water shall be available 24hrs a day free of charge.

#### Meeting rooms

At the team hotel all teams have the right to use a meeting room equipped with DVD player, projector and flip chart. A timetable is set up by the Organising Committee in order to reserve the meeting room for the times preferred. The teams are entitled to use this meeting room free of charge provided they respect the relevant timetable.

#### Visa

All teams have the right to be guaranteed trouble free entry into the hosting country. Visa assistance shall be provided by the Organising Committee.

#### Team guide

Team guides are at the disposal of each team. They form the link between the participating team concerned, the organiser and the IHF and assist the teams in all matters.

#### Local transportation

A heated/air-conditioned bus for local transportation for competition purposes from the day of arrival until the day of departure is available for each team.

#### Medical care

At each venue a comprehensive medical service (including 24-hour emergency) is available for every accredited participant.

#### Accreditation

All delegation members (for specifications refer to 2.9 team registration) shall have access to the field of play, the spectators' area and the media centre.



#### Executive team representative's rights

The head of delegation and one further member (to be defined by the national federation in advance) will receive further treatments (e.g. access to VIP zones, invitations to official receptions, etc.)

#### World Championship tickets

Each team has the right to buy / receive (in case free of charge) World Championship tickets. The amount of tickets available per team and the terms and conditions will be published in the official announcement.

#### VIP tickets

Further each participating federation receives a maximum of 2 VIP accreditation cards, including one ticket per accreditation to World Championship matches of its team. The participating federation has to announce the respective persons one month in advance. Unless announced in advance, they are not entitled to the named accreditation/ticket.

#### Match DVD

Each team shall receive a match DVD free of charge after every match in which the corresponding team has participated. DVDs of other matches can be purchased at a price of 30,- CHF.

#### Video recordings

One person per team and per venue is entitled to make video recordings for teaching and training purposes. Any person wishing to record a match must possess an accreditation card issued by the organiser. These video recordings must not be for commercial exploitation. A special authorization to make video recordings is not required; the Organising Committee however, shall issue the corresponding access authorization.

#### Match statistics

Teams have the right to receive the official match statistics of each World Championship match in printed or electronic form.

### **2.12. Duties of the participating teams**

Teams participating in IHF World Championships agree

- a) to comply with the IHF Statutes and Regulations
- b) to cooperate with the IHF and the organiser and to provide all requested data and information within the given deadline
- c) to respect the principles of fairness and fair play as defined in the IHF Statutes

- d) to comply with all competition-related decisions taken by the IHF Competition Management or any other competent body
- e) to promote handball in its best way and to avoid any inappropriate behaviour that might harm the reputation of handball in any way
- f) to be a role model and to stand for the ideological values of the handball family

Further all participating teams shall respect their event-related tasks such as

- g) announcing the requested data as published in the official announcement or in the present regulations on time (arrival, team photo, etc.)
- h) confirming that all players competing in the tournament fulfil the medical and physical conditions for participation (see 2.10.).

In case of non-compliance with these duties penalties and fines may be imposed.

### **2.13. Personality rights**

All participating teams grant the IHF the right to use photos and graphic materials of players and officials. Further, names and emblems of member federations may be used for event-related purposes.

All participating teams grant the IHF the right to use any kind of material produced for or at IHF World Championships for the promotion of IHF events and sport development projects.

### **2.14. IHF INFO**

In addition to the official announcement the IHF INFO brochure will be published prior to the event, which includes more detailed event-related information and the names and contact details of the IHF nominees in each venue.



## **ARTICLE 3**

---

### **III. Technical Section**

#### **3.1. Player eligibility**

The Player Eligibility Code shall apply. Players shall prove their citizenship by presenting a passport, which will be checked by the COC before the start of the World Championship. IHF shall check the eligibility of all players within one week after receiving the provisional lists.

The age limit for World Championships is 21 for men’s juniors, 20 for women’s juniors, 19 for men’s youth and 18 for women’s youth; meaning athletes aged 21, 20, 19 and 18 maximum accordingly in the year of the World Championship are eligible to participate.

Overview:

				Minimum age*	Maximum age
Women’s Championship	Youth (U18)	World		15 years	18 years
Women’s Championship	Junior (U20)	World		16 years	20 years
Men’s Youth	(U19)	World Championship		15 years	19 years
Men’s Junior	(U21)	World Championship		16 years	21 years

*\*Minimum age means that players eligible to participate have to reach the respective age in the respective category on the day of his/her first match at the latest.*

If a banned player is used, penalties and fines will be imposed. Please refer to the Regulations concerning Penalties and Fines, article 17.

### **3.2. Competition dates**

The IHF-COC shall fix the exact dates of the competitions with the following periods being set:

Women’s Youth (U18): August; taking place in even years

Women’s Junior (U20): July; taking place in even years

Men’s Youth (U19): August; taking place in odd years

Men’s Junior (U21): July; taking place in odd years

COC will add the exact dates to the international calendar. One week break shall be in between the youth and junior competitions.

The IHF Executive Committee shall confirm the dates of the tournament before the corresponding announcement being drawn up. In years of Olympic and Youth Olympic Games the event dates might be adapted according to the proposal of the COC.

### 3.3. Match scheme

24 teams – 4 preliminary round groups with 6 teams each

#### **Preliminary Round**

(Groups A, B, C and D) – (60 matches in total)

Matchday 1 1 – 4 2 – 6 3 – 5

Matchday 2 4 – 2 5 – 1 6 – 3

Matchday 3 1 – 6 2 – 3 4 – 5

Matchday 4 2 – 5 3 – 1 6 – 4

Matchday 5 5 – 6 3 – 4 1 – 2

*The teams ranked 1<sup>st</sup>–4<sup>th</sup> advance to the eighth-finals; the teams ranked 5<sup>th</sup>/6<sup>th</sup> compete for places 17–24.*

#### **Determination of places 17– 20 (4 matches in total)**

5.A – 5.B, 5.C – 5. D

*The winners compete for places 17/18; the losers compete for places 19/20.*

#### **Determination of places 21–24 (4 matches in total)**

6.A – 6.B, 6.C – 6. D

*The winners compete for places 21/22; the losers compete for places 23/24.*

#### **Placement matches (rank 17 – 24)**

In case of a draw at the end of the regular playing time direct 7m penalty throws shall be used to decide a winner in accordance with Rule 2:2 of the Rules of the Game.

#### **Eighth-Finals (8 matches in total)**

1.B – 4. A / EF 1

3.D – 2.C / EF 2

3.B – 2.A / EF 3

1.D – 4.C / EF 4

3.C – 2.D / EF 5

1.A – 4-B / EF 6

3.A – 2.B / EF 7

1.C – 4.D / EF 8

*The winners advance to the quarter-finals.*

The losers of the Eighth-Finals will compete in the placement matches 9–16.

*For this purpose a separate ranking of the teams concerned will be set up according to the following criteria:*

- a) number of points gained against the teams ranked 1<sup>st</sup>-4<sup>th</sup> in the preliminary round in their group;*
- b) if two or more teams have gained the same number of points the goal difference in the games mentioned under a) is decisive for the classification;*
- c) if two or more teams have gained the same number of points as well as the same goal difference in the games mentioned under a) a decision on the classification is made based on the greater number of plus goals in these games;*
- d) if two or more teams have gained the same number of points, the same goal difference and the same number of plus goals in the games mentioned under a) the classification of these teams is decided by lot through the competition management*

*Teams ranked 1<sup>st</sup> and 2<sup>nd</sup> in the corresponding ranking will play for places 9/10; teams ranked 3<sup>rd</sup> and 4<sup>th</sup> for places 11/12, etc.*

#### **Placement matches (9-16)**

15/16: 7<sup>th</sup> ranked – 8<sup>th</sup> ranked\*

13/14: 5<sup>th</sup> ranked – 6<sup>th</sup> ranked\*

11/12: 3<sup>rd</sup> ranked – 4<sup>th</sup> ranked\*

9/10: 1<sup>st</sup> ranked – 2<sup>nd</sup> ranked\*

\*according to the above mentioned ranking

In case of a draw at the end of the regular playing time direct 7m penalty throws shall be used to decide a winner in accordance with Rule 2.2 of the Rules of the Game.

#### **Quarter-Finals (4 matches in total)**

W EF 1 – W EF 2 / QF 1

W EF 3 – W EF 4 / QF 2

W EF 5 – W EF 6 / QF 3

W EF 7 – W EF 8 / QF 4

*The winners advance to the semi-finals; the losers compete in the placement round (5<sup>th</sup>-8<sup>th</sup> rank).*

#### **Placement Round (rank 5 – 8) (2 matches in total)\***

L QF 1 – L QF 2 / PR 5

L QF 3 – L QF 4 / PR 6

*The winners compete in the placement matches (5<sup>th</sup>-6<sup>th</sup>); the losers compete in the placement matches (7<sup>th</sup>/8<sup>th</sup>).*

**Placement Matches (2 matches in total)**

7/8 : L PR5 – L PR6

5/6 : W PR5 – W PR6

**Semi-Finals (2 matches in total)**

W QF 1 – W QF 2 / SF 1

W QF 3 – W QF 4 / SF 2

*The winners advance to the final; the losers compete for places 3/4.*

**Finals (2 matches in total)**

W SF 1 – W SF 2

L SF 1 – L SF 2

**Day by Day •**

0- Arrival of all teams	
1- Preliminary Round	(12 matches)
2- Preliminary Round	(12 matches)
3- Rest day	
4- Preliminary Round	(12 matches)
5- Preliminary Round	(12 matches)
6- Rest day	
7-Preliminary Round	(12 matches)
8-Rest day	
9-Eighth-Finals/Placement Round 17-24	(12 matches)
10-Quarter-Finals / Placement Matches 17-24 / Placement Matches 9-16	(12 matches)
11-Rest day	
12-Semi-Finals / Placement matches 5 – 8	(4 matches)
13-Finals / Placement matches 7/8, 5/6	(4 matches)
14-Departure	

*\*This is a general set-up. On request of media, TV or other international bodies, the IHF-COC may decide an alternative schedule, following the above-mentioned principles. Different rest days in the respective groups may be determined and placement round matches could be adapted to different days.*

Throw-off times

The throw-off times shall be fixed by the IHF in conjunction with the organiser and the TV rights-holder. Every team must be allocated a break of at least 20 hours between the throw-off times of one match and another.

### **3.4. Match evaluation and determination of places**

#### **3.4.1. Preliminary round**

The preliminary round is played in groups. The matches shall be evaluated as follows.

- each match won = 2 points
- each match drawn = 1 point for each team
- each match lost = no points

Teams are ranked according to the total number of points gained.

If two or more teams have gained the same number of points after the group matches have been completed, classification is decided as follows:

- results in points between the teams concerned
- goal differences in the matches between the teams concerned
- greater number of plus goals in the matches between the teams concerned.

If the teams are still equal, a decision is made between those teams with equal number of points as follows:

- goal difference is subtracted in all matches
- greater number of plus goals in all matches.

If classification still is not possible, a draw shall decide. The IHF representative on site shall execute the draw, if possible in the presence of the ‘responsible team officials’. If the ‘responsible team official’ cannot be present, other co-workers selected by the IHF shall take part.

#### **3.4.2. Placement matches, eighth-finals, quarter-finals, semi-finals and finals**

After completion of the preliminary round, the placement matches, eighth-finals, quarter-finals, semi-finals and finals shall be played in accordance with the knock-out system.

Overtime is played, following a 5-minute break, if a game is tied at the end of the regular playing time and a winner has to be determined. The overtime period consists of 2 halves of 5 minutes, with a 1-minute half-time break.

If the game is again tied after a first overtime period, a second period is played after a 5-minute break. This overtime period also has 2 halves of 5 minutes, with a 1-minute half-time break

Should the match still not be decided after the second overtime period, it is decided with 7m penalty throws in accordance with Rule 2.2 of the Rules of the Game.

The IHF-COC has the right to decide that certain matches will be executed with direct 7m penalty throws in accordance with Rule 2.2 of the Rules of the Game. If this rule applies, this decision will be published in the official announcement or together with the match schedule.

### **3.5. Cancellation or discontinuation of match**

If the match is cancelled or discontinued, the Competition Management shall decide on further action.

### **3.6. Official balls**

Only balls of the IHF partner will be used at IHF World Championships. All participating teams will receive training balls in advance to get familiar with the ball.

### **3.7. Players' uniform**

Only players' uniforms in accordance with the IHF Equipment Regulations are allowed. The approval procedure must be followed as laid down in the Equipment Regulations. Detailed specifications for players' uniforms including advertising rights and duties are laid down in the Equipment Regulations.

#### Implementing rules

At the Technical Meeting held prior to the start of the World Championship each delegation is obliged to show the two differently coloured sets of uniform.

In each match one team shall wear light-coloured shirts and the other team dark-coloured shirts.

For the preliminary round the colours have to be decided at the Technical Meeting before the matches. The decision of colours in each match will be taken with participation of the team representatives and the IHF Technical Delegates. In case of disagreement regarding the colours the team named first has the right to choose the colour.



The Competition Management decides the colours of the players' uniforms for all matches except for the preliminary round matches.

#### **3.7.1 Officials' clothing (team officials A-F)**

Specifications about the clothing of team officials are laid down in the Equipment Regulations.

#### **3.7.2. Referees' clothing**

Specifications about the clothing of referees are laid down in the Equipment Regulations.

### **3.8. Playing halls**

IHF competitions shall exclusively be held in playing halls complying with the IHF Regulations and the respective IHF Bid and Event Manual.

### **3.9. Training sessions**

One month before the start of the World Championship the training schedule, which has been submitted by the organiser and approved by the IHF, will be announced to the teams. The following specifications must be strictly adhered to:

- a) Each team must be granted the same conditions and has the right to train for at least 45 minutes every day. Furthermore all teams shall be entitled to at least one training session in the playing hall prior to its first match in the respective venue. In case training in the playing hall is not possible for extraordinary reasons, the IHF Competition Management may decide.
- b) The break between the training sessions of different teams should be 5 to 10 minutes.
- c) Training sessions may be used for training matches against other teams.
- d) The first 10 minutes of every training session in the respective main hall shall be open to the media. The teams are free to agree on complete training slots open to the media after consultation with the media representatives.
- e) Water for players will be provided during the training session. Further specifications are laid down in the IHF Bid and Event Manual (40. Training schedule).
- f) Each team must bring its own balls to the training hall. For this purpose the competition balls provided to the teams prior to the tournament and supplied by the IHF partner might be used.
- g) The Competition Management has the final decision on the training schedule.

### **3.10. Substitution area**

The IHF Substitution Area Regulations shall apply. No facilities and sport equipment (e.g. bicycles, barbells, etc.) are allowed in the substitution area for the warm-up.

### **3.11. Competition Management**

A Competition Management shall be formed, which is generally chaired by the COC Chairperson. Members are the PRC Chairperson and the CCM Chairperson. In case of absence of certain members the Executive Committee may nominate replacements.

The Competition Management is responsible for the orderly management of the event, in close cooperation with the organiser. It presents the first contact point for organisational issues. It gives advice and makes all the necessary decisions during the event, with the exception of disciplinary decisions. It is also responsible for the appointment of Officials, Technical Delegates and referees.

In the venues where the Competition Management is not present the body delegates the aforementioned tasks to the COC delegate (to be announced in IHF INFO, see 2.14.), who is supported by a member of the Head Office.

### **3.12. Referees / Technical Delegates / Officials**

The IHF nominees (Representatives, Officials, Delegates, Referees, etc.) are announced at the latest three months prior to the start of the World Championship.

### **3.13. Rules of the Game**

Matches shall be played according to the Rules of the Game currently valid. The IHF has the right to approve special rules valid for World Championships.

In general the following regulations are valid for all IHF events.

#### *16 players per match*

16 players may be put in per match at World Championships and related qualifying rounds.

#### *Half-time break*

The half-time break at World Championships shall be 15 minutes.

#### *Team-Time Out*

According to Rule 2:10 and Clarification 3 of the Rules of the Game each team has the right to receive a maximum of three team time-outs during regular playing time but not during overtime. No more than two team time-outs may be granted in each half of the regular playing time. Between two team time-outs of a team, the opponent must be at least once in possession of the ball. 3 green cards, bearing numbers 1, 2, and 3 respectively, are available for each team. The teams receive cards bearing numbers '1' and '2' in the first half of the game and

the cards no. 2 and no. 3 in the second half provided they received no more than one team time-out in the first half. In case they received two team time-outs in the first half, they receive only green card no. 3.

Within the last 5 minutes of the regular playing time only one team time-out per team is allowed.

### **3.14. Match Management**

One IHF Official and two IHF Technical Delegates shall form the Match Jury together with the timekeeper and scorekeeper appointed by the organiser. At least one of those two persons shall be fluent in English. The announcer shall be seated near the table.

### **3.15. Match supervision**

The match shall be under the IHF Official's full supervision.

### **3.16. Technical Meeting**

A Technical Meeting with the team officials of the participating delegations, the organiser and the IHF representatives shall be held at the beginning of the tournament. In this meeting, all necessary information will be provided and organisational, technical and financial issues can be settled. Furthermore the definitive registration lists will be approved and the uniform colours for the preliminary round will be determined.

Further Technical Meetings might be held if required.

### **3.17. Doping tests**

Doping tests shall be carried out according to the IHF Anti-Doping Regulations.

### **3.18. Scouting system**

The IHF and the organiser assure the data processing to produce all match-relevant statistics.



## **ARTICLE 4**

---

### **IV. Legal Section**

Any disputes arising during a competition shall be dealt by the IHF appeal authorities. The procedure of raising protests and appeals and further specifications are laid down in the Legal Provisions. In addition the IHF will describe the procedures that apply for the relevant event in the corresponding official announcement.



## V. Financial Section

### 5.1. Expenses to be borne by the participating teams.

#### Travel expenses

Travel expenses for the entire participating delegation. The IHF shall fix the place of arrival and departure in close cooperation with the organiser and publish it in the official announcement.

#### Cost of visas

Participants shall bear all costs in connection with obtaining necessary visas.

#### Registration fee

Nations taking part in the WCh tournament shall pay the IHF a registration fee of CHF 500.– The payment deadline is the same date as the registration deadline.

#### Participation fee

Nations taking part in the WCh tournament shall pay a participation fee per person / day to the IHF (21 persons; 16 players and 5 officials). The participation fee is set individually when awarding the championship based on the documents submitted by the organiser at the awarding Congress.

#### Fixed deposit

All participants shall pay the IHF, at the same time as the registration fee, a deposit of CHF 5,000.– which will be taken on account or repaid. If a registering federation has the uncharged sum of CHF 5,000.– on its account with the IHF, this may be used as the fixed deposit. The federation's IHF account will be credited with the relevant sum after the WCh. If the country withdraws, the sum shall be forfeited to the benefit of the IHF.

During the World Championship the IHF has the right to freely dispose of the fixed deposit of each team and may use it to pay fees, fines or other financial obligations of the corresponding federation.

#### Accident and sickness insurance

Federations taking part at World Championships are obliged to insure all delegation members, i. e. all players and all officials, against accident and sickness, at their own cost. The organiser and the IHF shall not be held liable for any accidents that occur or any sickness.

### Days of stay

When calculating the participation fee, the number of days is generally counted from 12 noon on the day of arrival to 12 noon on the day of departure, i.e. although the days of arrival and departure make up two calendar days, they represent only one fee-paying day. (Additional meals – on the day of arrival possibly breakfast, on the day of departure possibly lunch and/or supper – shall be paid for in addition.) Arrival day is generally one day prior to the first match and departure day one day after the last match of the corresponding team.

### Additional days of stay/ additional participants (22<sup>nd</sup> – 30<sup>th</sup> team member)

Participating teams may arrive earlier, leave later or stay during the World Championship period although they have been eliminated from the competition, but they must bear the additional costs themselves. This regulation applies for the World Championship period, 3 days prior and 2 days after as a maximum. For those additional days for 21 persons (16 players and 5 officials) the same amount (as the from the Congress confirmed participation fee) has to be paid.

For all additional days outside the 3+2 period as well as for all days of stay – also during the WCh period – of potential additional participants (22<sup>nd</sup> – 30<sup>th</sup> team member), the OC may set another daily rate.

## **5.2. Expenses to be borne by the organiser**

### Expenses in the host country

All expenses arising within the host country in connection with the games.

### Board and lodging

Full board and lodging for a maximum of 21 persons (up to 16 players and the remainder as officials) per federation, starting one day before the World Championship and finishing one day after the team's last match.



## **ARTICLE 6**

---

## **VI. Television, media and advertising**

### Television, film and video rights, advertising at the playing halls

The IHF alone shall hold these rights. The corresponding agreements shall be made with the respective organiser.

The IHF shall receive the revenues from television, film and video and income from advertising at the halls.

Advertising on sportswear

Rights in respect of advertising on sportswear are laid down in the Regulations on Advertising and the Equipment Regulations.

Video recordings

After the end of the WCh tournament the organiser shall provide the IHF with video recordings of all matches free of charge.



## ARTICLE 7

---

### **VII. Awards and ceremonies**

Pre- and post-match procedure

The procedure before and after the match will be published in the official announcement. All parties involved shall strictly adhere to these guidelines.

Opening and closing ceremony

The opening and closing ceremonies shall be of reasonable and appropriate proportions. Details are contained in the List of Duties for Official IHF Competitions and the IHF Bid and Event Manual.

Winners (places 1 – 3)

Medals and certificates shall be awarded to the three top teams as follows:

- 1<sup>st</sup> place and World Champion (gold)
- 2<sup>nd</sup> place (silver)
- 3<sup>rd</sup> place (bronze)

On the podium a total of 21 persons are allowed (players who have participated in the World Championship and team officials A-E).

All other players and officials of the teams ranked 1 – 3 shall also receive the corresponding medals up to a maximum number of 25 medals.

All other teams shall receive a souvenir medal.

Head Office

One set of medals and certificates shall be preserved in the IHF Head Office archives.

At the World Championships, the following official awards shall be presented.

**a) Player of the Match**

The IHF has the right to award the most valuable player in every World Championship match who shall receive the Player of the Match award. The IHF-CCM (or its representatives) shall decide about the awarding of the player.

**b) All-Star Team**

The IHF All-Star Team will be designated by the IHF-CCM experts attending the World Championship and will be announced after the final.

**c) Top Scorer**

The player who has scored the largest number of goals during the entire World Championship tournament shall receive the IHF Top Scorer award. If two or more players have scored the same number of goals, the number of assists will be decisive.

**d) Most Valuable Player (MVP)**

The best player of the tournament shall receive the MVP award. The MVP will be designated by the IHF-CCM experts attending the World Championship.

No other awards than the aforementioned shall be presented at the World Championship.



**ARTICLE 8**

---

**VIII. Closing comment**

Further provisions regarding organisation are stipulated in the IHF Bid and Event Manual. Should any problems arise at Women's Youth (U18) and Junior (U20) and Men's Youth (U19) and Junior (U21) World Championships that are not covered by the present Regulations, the Competition Management shall decide. In case of non-observance of these Regulations, Regulations concerning Penalties and Fines (XIX) shall apply.

4.

**Olympic Games**





## ARTICLE 1

---

### I. Hosting

Awarding the Olympic Games is reserved to the International Olympic Committee. Basic principles for the preparation and staging of the Olympic Handball Tournaments are laid down in the IHF Event Manual and the Requirements Document of the Olympic Results and Information Services (ORIS).



## ARTICLE 2

---

### II. Administrative Section

#### 2.1. General principles

The International Olympic Committee (IOC) regulations or those of the organiser charged by the IOC shall apply at Olympic Handball Tournaments and shall always take precedence over the regulations of the IHF. The National Olympic Committee concerned will publish and announce them.

#### 2.2. Number of participants

The number of participants at Men's and Women's Olympic Handball Tournaments shall be 12 teams.

#### 2.3. Quota places

The 12 teams participating at the Olympic Handball Tournament are composed as follows:

Organiser:	one (1)
Reigning World Champion:	one (1)•
Continental Qualifications (4 quota places):	
Asia	one (1)
Africa	one (1)
Europe	one (1)
Pan-America	one (1)

The best ranked team at the respective continental qualifying event is eligible to take part.\*\*

IHF Qualification Tournaments (6 quota places) :

**Tournament 1** two (2)

**Tournament 2** two (2)

**Tournament 3** two (2)

The two best ranked team at each tournament are eligible to take part.

\*If the organiser is the World Champion, the second-ranked national team of the respective World Championship shall take the place.

\*\*In the event that the reigning World Champion (or the host nation) wins the continental qualifying event, the second ranked team of the respective continental qualification event will obtain a quota place.

The 12 teams will be seeded in the performance rows as follows:

1	World Champion	Team ranked first at qualification tournament 1
2	Team ranked first at qualification tournament 2	Team ranked first at qualification tournament 3
3	Team ranked second at qualification tournament 3	Team ranked second at qualification tournament 2
4	Team ranked second at qualification tournament 1	Organiser
5	*	*
6	*	*

*\*These places are allocated to the continental qualifiers. The order of these places for the corresponding continental representatives will be established according to the ranking of the continents at the World Championship, taking place in the year prior to the Olympic Games.*

*The IHF reserves the right to change the tournament mode of the IHF qualification tournament at any time. This might lead to further changes of the existing regulations.*

#### **2.4. Qualifying for Olympic Games**

The IHF owns the rights to Olympic Games qualifications. As laid down in the IHF Statutes, qualifying shall be through the continents (with the exception of the organiser) and the IHF Qualification Tournaments according to clearly regulated performance criteria and other necessary regulations defined by the IHF.

#### **2.5. Qualifying dates**

As a matter of principle, continental qualifying rounds for Olympic Games must be completed no later than 2 months before start of the Olympic Handball Tournaments.

The continental confederations shall include their qualifying rounds to the Olympic Games in the IHF calendar.

#### **2.6. Registration**

Upon completion of qualifications the continental confederations are obliged to inform the IHF Head Office within one (1) week about the ranking, the teams qualified and the substitute nations.

Following each qualifying event the IHF will contact the respective national federations to confirm that they have obtained a quota place. In compliance with the Olympic Qualification System for Handball, the respective national federations then have to confirm to the IHF and the IOC through their NOCs within two weeks, if they wish to use these quota places. The same applies for the reigning World Champion.

Teams participating at the Olympic Qualification Tournaments automatically confirm their participation at the respective Olympic Games in case qualified and acknowledge at the same time to fulfil all rights and duties resulting from the qualification.

#### **2.7. Draw**

The draw, held by the IHF (COC), shall be in compliance with the performance criteria. The organiser shall have a free choice of its preliminary round group within its performance row that is drawn last.

## **2.8. Non-appearance**

If the team of a federation that has qualified for the Olympic Games does not take part, the quota place will be reallocated to the next best ranked national federation at the event where the initial quota place was obtained.

If the host country declines either of its allocated quota places, they will be reallocated to the continent of the winning team of the same gender at the preceding IHF World Championship, and specifically to the best ranked national federation at the respective continental championship that has yet to qualify.

## **2.9. Team registration**

Team registration for the Olympic Handball Tournaments consists of the following steps:

- Sport entries  
Sport entries must be done through the corresponding NOC, which will also provide all required information in this regard.
- Provisional registration list ('list of 28')  
The 'list of 28' must be submitted to the IHF one month before the start of the Olympic Handball Tournament at the latest. Players in this list have to be included in the sport entries already submitted before.
- Final registration  
Final registration is done through the corresponding NOC. Hereby all teams have to select the players (number of players per team according to IOC regulations) from the 'list of 28'. Deadlines and conditions will be communicated by the NOCs.

The provisional registration, on the relevant IHF form, must include:

- a) officials (who should not be changed during the entire competition) with the following details: surname, first name, date of birth, nationality, gender, function within the delegation and indication of the officials (by use of letters A, B, C, D, E, F);  
the following functions must be used: head coach, assistant coach, physiotherapist, doctor, team official
- b) players with the following details: players' number, surname, first name, club, date of birth, height, weight, throwing hand, main position, number of international games, number of goals scored in international matches
- c) colour of players' uniforms (see Equipment Regulations for detailed specifications)

In case of submitting incorrect or incomplete forms fines may be imposed.

### Provisional registration

Even if a team has registered less than 28 players, the provisional list is final and cannot be changed once the deadline has expired.

### Player replacement

All player replacements can only be done according to IOC regulations. IOC regulations in this regard have priority.

As a general rule, all teams may exchange an unlimited number of players until the technical meeting, but in any case the Late Athlete Replacement Policy has to be respected.

During the competition (after the technical meeting) all teams are entitled to

- replace one player with any player from the Long list and the IHF provisional registration list ('list of 28') up until the quarter-finals;
- replace on one occasion a goalkeeper with another goalkeeper on the Long list and the IHF provisional registration list ('list of 28') up until the final;
- replace any player with the P alternate athlete up until the final.

In any case the replaced player cannot return to the roster.

### *Procedure for player replacement*

The replacement of a player has to be announced on the day before the respective match. Detailed information on the procedure for late athlete replacement will be provided by the IOC.

### **2.10. Formal confirmation of participation**

All qualified federations have to confirm their participation at the Olympic Games in writing within the set deadline in the Qualification System Principles issued by the IOC. The deadline is normally two weeks after the end of the respective qualification.

Further the participating nations are held to confirm that all players competing in the tournament fulfil the medical and physical conditions for participation. For that purpose the players to compete in the Olympic Games shall undergo a medical exam in advance in order to receive a certificate of health. By use of the corresponding form the federations concerned shall confirm its players' health status saying that they have received such certificate and fulfil the medical and physical conditions to compete at the event.

### **2.11. Rights of participating teams**

All rights regarding logistics and organizational matters are laid down in the respective IOC regulations. The IHF is recommending to the IOC and the respective organiser that all handball specific regulations are very similar to the standards of the World Championships.

### **2.12. Duties of the participating teams**

Teams participating at the Olympic Games agree

- a) to comply with the IHF Statutes and Regulations and the provisions of the Olympic Charta
- b) to cooperate with the IHF and the organiser and to provide all requested data and information within the given deadline
- c) to respect the principles of fairness and fair play as defined in the IHF Statutes
- d) to comply with all competition-related decisions taken by the IHF Competition Management or any other competent body
- e) to promote handball in its best way and to avoid any inappropriate behaviour that might harm the reputation of handball in any way
- f) to be a role model and to stand for the ideological values of the handball family

Further all participating teams shall respect their event-related tasks such as

- g) announcing the requested data as communicated or published in the present regulations on time (arrival, team photo, etc.)
- h) confirming that all players competing in the tournament fulfil the medical and physical conditions for participation (see 2.10.)

### **2.13. Personality rights**

All participating teams grant the IHF and the IOC the right to use photos and graphic materials of players and officials. Further, names and emblems of member federations may be used for event-related purposes.

All participating teams grant the IHF and the IOC the right to use any kind of material produced at Olympic Games for the promotion of IHF and IOC events and sport development projects.



### III. Technical Section

#### 3.1. Player eligibility

All players taking part at the Olympic Games must comply with the provisions of the current IOC Olympic Charter and must be eligible to play for their national team as per IHF Regulations.

The Player Eligibility Code shall apply. Players shall prove their citizenship by presenting a passport, which will be checked by the COC before the start of the tournament.

The minimum age of 16 is fixed for the participation at the Olympic Handball Tournaments, meaning that players eligible to participate have to turn 16 years on the day of his/her first match at the latest.

If a banned player is used, penalties and fines will be imposed. Please refer to the Regulations concerning Penalties and Fines, article 17.

#### 3.2. Competition dates

The date of the Olympic Games is fixed by the IOC and will be included in the IHF World Calendar as soon as the date is known.

#### 3.3. Match scheme

12 teams – 2 preliminary round groups with 6 teams each

##### **Preliminary Round**

(Groups A and B – 30 matches in total)

Matchday 1	1 – 4	2 – 6	3 – 5
Matchday 2	4 – 2	5 – 1	6 – 3
Matchday 3	1 – 6	2 – 3	4 – 5
Matchday 4	2 – 5	3 – 1	6 – 4
Matchday 5	5 – 6	3 – 4	1 – 2

*The four best placed teams in each group will advance to the quarter-finals. The teams ranked 5<sup>th</sup> in each preliminary round group will be ranked in 9<sup>th</sup> and 10<sup>th</sup> places; the teams ranked 6<sup>th</sup> will be ranked in 11<sup>th</sup> and 12<sup>th</sup> places (see 3.4. for the exact determination of rankings).*

After the preliminary round, the competition follows a straight knockout format, with quarter-finals, semi-finals, a bronze medal match and a gold medal match.

### **Quarter-finals (4 matches in total)**

1.A – 4.B (Quarter-Final 1 / QF1)

3.B – 2.A (Quarter-Final 2 / QF2)

3.A – 2.B (Quarter-Final 3 / QF3)

1.B – 4.A (Quarter-Final 4 / QF4)

*The winners of the quarter-finals advance to the semi-finals. The losers will be ranked 5<sup>th</sup> – 8<sup>th</sup> (see 3.4).*

### **Semi-Finals (2 matches in total)**

W QF 1 – W QF 2 / SF 1

W QF 3 – W QF 4 / SF 2

*The winners advance to the final; the losers compete for places 3/4.*

### **Finals (2 matches in total)**

W SF 1 – W SF 2

L SF 1 – L SF 2

### **Day by Day •**

0-	Arrival of all teams	
1-	Preliminary Round – Women’s tournament	(6 matches)
2-	Preliminary Round – Men’s tournament	(6 matches)
3-	Preliminary Round – Women’s tournament	(6 matches)
4-	Preliminary Round – Men’s tournament	(6 matches)
5-	Preliminary Round – Women’s tournament	(6 matches)
6-	Preliminary Round – Men’s tournament	(6 matches)
7-	Preliminary Round – Women’s tournament	(6 matches)
8-	Preliminary Round – Men’s tournament	(6 matches)
9-	Preliminary Round – Women’s tournament	(6 matches)
10-	Preliminary Round – Men’s tournament	(6 matches)
11-	Quarter-Finals – Women’s tournament	(4 matches)
12-	Quarter-Finals – Men’s tournament	(4 matches)
13-	Semi-Finals – Women’s tournament	(2 matches)
14-	Semi-Finals – Men’s tournament	(2 matches)
15-	Finals – Women’s tournament	(2 matches)
16-	Finals – Men’s tournament	(2 matches)



## 17- Departure

*\*This is a general set-up. On request of media, TV or other international bodies, the IHF-COC may decide an alternative schedule, following the above-mentioned principles.*

### Throw-off times

The throw-off times shall be fixed by the IOC in conjunction with the organiser and the Olympic Broadcasting Service. Every team must be allocated a break of at least 20 hours between the throw-off times of one match and another.

## **3.4. Match evaluation and determination of places**

### **3.4.1. Preliminary round**

The preliminary round is played in groups. The matches shall be evaluated as follows:

- each match won = 2 points
- each match drawn = 1 point for each team
- each match lost = no points

Teams are ranked according to the total number of points gained.

If two or more teams have gained the same number of points after the group matches have been completed, classification is decided as follows:

- results in points between the teams concerned
- goal differences in the matches between the teams concerned
- greater number of plus goals in the matches between the teams concerned.

If the teams are still equal, a decision is made between those teams with equal number of points as follows:

- goal difference is subtracted in all matches
- greater number of plus goals in all matches.

If classification still is not possible, a draw shall decide.

The IHF representative on site shall execute the draw, if possible in the presence of the 'responsible team officials'. If the responsible team official cannot be present, other co-workers selected by the IHF shall take part.

#### Determination of places 9–12

The teams ranked 5<sup>th</sup> in each preliminary round group will be ranked in 9<sup>th</sup> and 10<sup>th</sup> places; the teams ranked 6<sup>th</sup> will be ranked in 11<sup>th</sup> and 12<sup>th</sup> places. Determination of these places is done by calculation according to the following evaluation criteria:

- a) Number of points gained
- b) In case of equal number of points the goal difference in the preliminary round shall decide.
- c) In case of equal number of points and the same goal difference the larger number of plus goals in the preliminary round shall decide.
- d) If classification is not possible according to points a–c decision shall be made by drawing lots

#### **3.4.2. Quarter-finals, semi-finals and finals**

After completion of the preliminary round, the quarter-finals, semi-finals and finals shall be played in accordance with the knock-out system.

Overtime is played, following a 5-minute break, if a game is tied at the end of the regular playing time and a winner has to be determined. The overtime period consists of 2 halves of 5 minutes, with a 1-minute half-time break.

If the game is again tied after a first overtime period, a second period is played after a 5-minute break. This overtime period also has 2 halves of 5 minutes, with a 1-minute half-time break

Should the match should not be decided after the second overtime period, it is decided with 7m penalty throws in accordance with Rule 2:2 of the Rules of the Game.

#### Determination of places 5–8

The losers of the quarter-finals will be ranked 5<sup>th</sup>–8<sup>th</sup>. This ranking is done by calculation according to the following evaluation criteria:

- a) The ranking will be done according to the places of the preliminary round. If two or more teams were ranked on the same place in the preliminary round, the number of points gained in the preliminary round will decide.
- b) In case of equal number of points the goal difference in the preliminary round shall decide.
- c) In case of equal number of points and the same goal difference the larger number of plus goals in the preliminary round shall decide.

d) If classification is not possible according to points a–c, decision shall be made by draw.

### **3.5. Cancellation or discontinuation of match**

If the match is cancelled or discontinued, the Competition Management shall decide on further action.

### **3.6. Official balls**

Only balls of the IHF partner will be used at the Olympic Handball Tournaments. All participating teams will receive training balls in advance to get familiar with the ball.

### **3.7. Clothing and equipment**

Clothing and equipment used by athletes and other participants in the competition at the Olympic Games must comply with the documents listed below:

- IHF Rules of the Game, with particular reference to Rules 4.7.–4.9 (Equipment)
- IHF Statutes and Regulations, with particular reference to the IHF Equipment Regulations, where the approval procedure for players' clothing is laid down, which must be followed.
- IOC Olympic Charter: Rule 50 (Advertising, Demonstrations, Propaganda) and the Bylaw to Rule 50
- IOC Guidelines Regarding Authorised Identifications for the corresponding Olympic Games

#### Implementing rules

At the Technical Meeting held prior to the start of the Olympic Handball Tournament each delegation is obliged to show the three differently coloured sets of uniform.

In each match one team shall wear light-coloured shirts and the other team dark-coloured shirts.

For the preliminary round the colours have to be decided at the Technical Meeting before the matches. The decision of colours in each match will be taken with participation of the team representatives and the IHF Technical Delegates. In case of disagreement regarding the colours the team named first has the right to choose the colour.

The Competition Management decides the colours of the players' uniforms for all matches except for the preliminary round matches.

### **3.8. Playing halls**

IHF competitions shall exclusively be held in playing halls complying with the IHF Regulations.

### **3.9. Training sessions**

The Organiser of the Olympic Games is preparing the training schedule. The following specifications must be strictly adhered to:

- a) Each team must be granted the same conditions and has the right to train for at least 45 minutes every day. Furthermore all teams shall be entitled to at least one training session in the playing hall prior to its first match in the respective venue. In case training in the playing hall is not possible for extraordinary reasons, the IHF Competition Management may decide.
- b) The break between the training sessions of different teams should be 5 to 10 minutes.
- c) Training sessions may be used for training matches against other teams.
- d) Water for players will be provided during the training session.
- e) The Competition Management has the final decision on the training schedule.

### **3.10. Substitution area**

The IHF Substitution Area Regulations shall apply. No facilities and sport equipment (e.g. bicycles, barbells, etc.) are allowed in the substitution area for the warm-up.

### **3.11. Competition Management**

A Competition Management shall be formed, which is generally chaired by the COC Chairperson. Members are the PRC Chairperson and the CCM Chairperson. In case of absence of certain members, the Executive Committee may nominate replacements or the present Technical Delegates as members of the Competition Management.

The Competition Management is responsible for the orderly management of the event, in close cooperation with the organiser. It represents the first contact point for organisational issues. It gives advice and makes all the necessary decisions during the event, with the exception of disciplinary decisions. It is also responsible for the appointment of Officials, Technical Delegates and referees.

In the venues where the Competition Management is not present the body delegates the aforementioned tasks to the COC delegate (to be announced prior to the event), who is supported by a member of the Head Office.

### **3.12. Referees / Technical Delegates / Officials**

The IHF nominees (Representatives, Officials, Delegates, Referees, etc.) are announced at the latest three months prior to the start of the Olympic Handball Tournaments.

### **3.13. Rules of the Game**

Matches shall be played according to the Rules of the Game currently valid.

In general the following regulations are valid for Handball Olympic Tournaments.

#### *Players per match*

The number of players to be put in per match at Handball Olympic Tournaments is fixed by the IOC.

#### *Half-time break*

The half-time break at the Olympic Games shall be 15 minutes.

#### *Team-Time Out*

According to Rule 2.10 and Clarification 3 of the Rules of the Game each team has the right to receive a maximum of three team time-outs during regular playing time but not during overtime. No more than two team time-outs may be granted in each half of the regular playing time. Between two team time-outs of a team, the opponent must be at least once in possession of the ball. 3 green cards, bearing numbers 1, 2, and 3 respectively, are available for each team. The teams receive cards bearing numbers '1' and '2' in the first half of the game and the cards no. 2 and no. 3 in the second half provided they received no more than one team time-out in the first half. In case they received two team time-outs in the first half, they receive only green card no. 3.

Within the last 5 minutes of the regular playing time only one team time-out per team is allowed.

### **3.14. Match Management**

One IHF Official and two IHF Technical Delegates shall form the Match Jury together with the timekeeper and scorekeeper appointed by the organiser. At least one of those two persons shall be fluent in English. The announcer shall be seated near the table.

### **3.15. Match supervision**

The match shall be under the IHF Official's full supervision.

### **3.16. Technical Meeting**

A Technical Meeting with the team officials of the participating delegations, the organiser and the IHF representatives shall be held at the beginning of the tournament. In this meeting, all necessary information will be provided and organisational, technical and financial issues can

be settled. Furthermore the definitive registration lists will be approved and the uniform colours for the preliminary round will be determined.

Further Technical Meetings might be held if required.

### **3.17. Doping tests**

Doping tests shall be carried out with the guidance of the IOC in accordance with the IOC Anti-Doping-Rules and in compliance with the World Anti-Doping Code and its relevant International Standards.

### **3.18. Scouting system**

The IHF and the organiser assure the data processing to produce all match-relevant statistics.



## **ARTICLE 4**

---

### **IV. Legal Section**

Any disputes arising during a competition shall be dealt with by the IHF appeal authorities. The procedure of raising protests and appeals and further specifications are laid down in the Legal Provisions. In addition the IHF will describe the procedures that apply for the relevant event in the corresponding official announcement.



## **ARTICLE 5**

---

### **V. Awards and ceremonies**

Pre- and post-match procedure

The procedure before and after the match will be announced in due time before the start of the tournament. All parties involved shall strictly adhere to these guidelines.

Winners (places 1 – 3)

Medals and certificates shall be awarded in accordance with the IOC Olympic Charter (Rule 56: Victory, Medals and Diplomas Ceremonies) and the IOC Technical Manual on Protocol as follows:

- 1<sup>st</sup> place  
A silver gilt medal, a certificate and an Olympic medallist's pin
- 2<sup>nd</sup> place  
A silver medal, a certificate and an Olympic medallist's pin
- 3<sup>rd</sup> place  
A bronze medal, a diploma and an Olympic medallist's pin
- Fourth, fifth, sixth, seventh and eighth places  
A diploma

Each team will receive a maximum of medals as announced by the IOC.

All other teams as well as the nominees and referees acting on behalf of the IHF shall receive a souvenir medal.

At the end of Men's and Women's Olympic Handball Tournaments, the following official awards shall be presented.

**a) All-Star Team**

The IHF All-Star Team will be designated by the IHF-CCM experts attending the Olympic Games and will be announced after the final.

**b) Top Scorer**

The player who has scored the largest number of goals during the entire Olympic Handball Tournament shall receive the IHF Top Scorer award. If two or more players have scored the same number of goals, the number of assists will be decisive.

**c) Most Valuable Player (MVP)**

The best player of the tournament shall receive the MVP award. The MVP will be designated by the IHF-CCM experts attending the Olympic Games.

No other awards than the aforementioned shall be presented at the end of the Olympic Handball Tournament.



**VI. Closing comment**

Further provisions regarding organisation are stipulated in the IHF Event Manual. Should any problems arise at Olympic Handball Tournaments that are not covered by the present Regulations, the Competition Management shall decide. In case of non-observance of these Regulations, Regulations concerning Penalties and Fines (XIX) shall apply.



**5.**

**Olympic Qualification**

**Tournaments**



## ARTICLE 1

---

### **I. Hosting**

The hosts of the Olympic Qualification Tournaments are appointed according to the respective regulations drawn up by the IHF Council for Olympic Qualification Tournaments. The regulations and obligations for hosting the event are laid down in the IHF Event Manual which forms the basic principles for the preparation and staging of Olympic Qualification Tournaments.



## ARTICLE 2

---

### **II. Administrative Section**

#### **2.1. Announcement**

The IHF Head Office shall announce Olympic Qualification Tournaments at least 2 months before the start, with reference to the Statutes and the Regulations for IHF Competitions. This announcement will be sent to the participating federations and will contain, in large parts, information laid down in the Competitions section of the IHF Statutes and Regulations, but also more specific information about the event including all dates and deadlines which shall be respected.

#### **2.2. Number of tournaments and participants**

For each forthcoming Olympic Games three Olympic Qualification Tournaments per gender will be held. Twelve Men's and twelve Women's teams will compete at their respective Olympic Qualification Tournaments.

#### **2.3. Eligibility of teams to participate at Olympic Qualification Tournaments**

The 12 teams eligible to participate at Men's and Women's Olympic Qualification Tournaments are seeded as follows.

Tournament 1	Tournament 2	Tournament 3
2 <sup>nd</sup> -ranked team	3 <sup>rd</sup> -ranked team	4 <sup>th</sup> -ranked team
7 <sup>th</sup> -ranked team	6 <sup>th</sup> -ranked team	5 <sup>th</sup> -ranked team
3 <sup>rd</sup> best continent (QS 3)	2 <sup>nd</sup> best continent (QS 2)	Best continent (QS 1)
4 <sup>th</sup> best continent (QS 4)	Best continent (QS 5)	2 <sup>nd</sup> best continent (QS 6)

*\*QS= Qualification Slot for the IHF Olympic Qualification Tournament*

QS 1 and 5 will be allocated to the best placed continent at the preceding World Championship. The best ranked team (QS1) and next best ranked team (QS5) at the respective Continental Qualification event not yet qualified and not yet selected to participate in the IHF Qualification Tournaments will earn the Qualification slot.

QS 2 to 4 are allocated to the second (QS2), third (QS3) and fourth (QS4) best placed continents at the preceding World Championship. The best ranked teams at the respective Continental Qualification event not yet qualified and not yet selected to participate in the IHF Qualification Tournaments will earn the Qualification slot.

QS 6: If any team from Oceania is ranked between 8<sup>th</sup> –12<sup>th</sup> at the preceding World Championship, this Qualification slot will be allocated to the best NOC at the Oceania Qualification event not yet qualified. If this is not the case, this Qualification slot will be allocated to second best ranked continent at the preceding World Championship, in addition to QS2. The NOC of the best ranked team at the respective Continental Qualification event, not yet qualified, will be allocated the Qualification slot.

If one (1) or more teams ranked between 2<sup>nd</sup> – 7<sup>th</sup> at the preceding World Championship have already qualified for the Olympic Games at their respective Continental Qualification events, the team ranked 8<sup>th</sup> (or thereafter) at the preceding World Championship will be eligible to participate in the Olympic Qualification Tournaments.

#### **2.4. Qualifying for Men’s and Women’s Olympic Qualification Tournaments**

The IHF owns the rights to Olympic Qualification Tournaments. As laid down in the IHF Statutes, qualifying shall be to clearly regulated performance criteria and other necessary regulations defined by the IHF.

## **2.5. Qualifying dates**

As a matter of principle, continental qualifying rounds for Olympic Qualification Tournaments must be completed no later than 2 months before the tournament start.

The continental confederations shall include their qualifying rounds to the Olympic Qualification Tournaments in the IHF calendar.

## **2.6. Registration**

National federations which have earned qualification to the Olympic Qualification Tournaments through their respective continental qualification event shall give a binding agreement to the IHF to accept the places open to them at the latest two weeks after the end of the continental qualification event.

The participants have to pay a deposit and a registration fee to the IHF. Details hereto are laid down in the Financial Section (Article 5). If these deadlines are not met, eligibility to participate shall lapse. In such a case, the substitute nation nominated by the continental confederation shall be eligible to play.

Failure to meet payment dates

If a federation does not meet the payment dates for an IHF event, additional fines may be imposed. Repeated payment failure can result in the exclusion of the federation from the corresponding IHF event. Specifications and consequences in case of failure to meet payment dates are laid down in the Regulations concerning Penalties and Fines.

## **2.7. Non-appearance**

If the team of a federation that has qualified for the Olympic Qualification Tournament does not take part, the place will be reallocated to the next best ranked national federation at the event where the initial place to participate at the Olympic Qualification Tournament was obtained.

## **2.8. Team registration**

Delegations may consist of up to 30 persons. The participating federation must bear the costs of delegation members ranked 22<sup>nd</sup> to 30<sup>th</sup> in the list. These delegation members have the same rights and duties (usage of organized transport, accreditation, meals, etc.) as the first 21 ranked delegation members, in case they have been officially registered by the corresponding national federation and the conditions and requirements outlined by the organiser have been respected. In case the participating federation fails to pay the fixed fee for additional participants, these additional participants are not entitled to use the services included in the

rights of participating teams (accommodation, meals, transportation, medical care, etc.), laid down in 2.11. of the present document.

Players and the remainder as officials (stating their function) shall be registered as follows:

- provisionally: one month before the Olympic Qualification Tournament at the latest (28 players at most) to the organiser as well as the IHF Head Office
- definitively: one hour before the Technical Meeting to the responsible IHF representative (16 players taken from the provisional list and five (5) officials). The registration must be executed with help of the relevant IHF form (see Annex 1).

The registration, on the relevant IHF form, must include:

- a) officials (who should not be changed during the entire competition)\* with the following details: surname, first name, date of birth, nationality, gender, function within the delegation and indication of the officials (by use of letters A, B, C, D, E, F);  
the following functions must be used: head coach, assistant coach, physiotherapist, doctor, team official  
*\*In exceptional cases the IHF Competition Management may allow the replacement of up to two officials during competition on request of the NF concerned (e.g. in case of serious health issues).*
- b) players with the following details: players' number, surname, first name, club, date of birth, height, weight, throwing hand, main position, number of international games, number of goals scored in the relevant World Championship category
- c) colour of players' uniforms (see Equipment Regulations for detailed specifications)

In case of submitting incorrect or incomplete forms fines may be imposed.

#### Provisional registration

Even if a team has registered less than 28 players, the provisional list is final and cannot be changed once the deadline has expired.

#### Player replacement

During the Olympic Qualification Tournament each team may replace up to three players (against three players indicated in the provisional list) at any time (e.g. each team may put in three new players or may put in a player who has already been replaced once). Players may be replaced against players indicated in the provisional delegation list ('list of 28') only.

In case a suspended player is replaced by another player, the new player is only eligible to play after the suspension has lapsed.

If a team has registered less than 16 players, it may register one additional player during the Olympic Qualification Tournament.

*Procedure for late registration or substitution of one or several players.*

New players must be orally registered to the Competition Management or the responsible IHF delegate in the corresponding venue at 9.00 am on the respective matchday at the latest. A written registration and a proof of citizenship (passport, etc.) shall follow one hour before the match at the latest. The official IHF form must be used. (see Annex 2)

### **2.9. Formal confirmation of participation**

All qualified federations have to confirm their participation at Men's and Women's Olympic Qualification Tournaments in writing by use of the corresponding form attached to the official announcement. Further the participating nations are held to confirm that all players competing in the tournament fulfil the medical and physical conditions for participation. For that purpose the players to compete in the World Tournament shall undergo a medical exam in advance in order to receive a health certificate. By use of the corresponding form the federations concerned shall confirm its players' health status saying that they have received such certificate and fulfil the medical and physical conditions to compete at the Olympic Qualification Tournament.

### **2.10. Rights of participating teams**

All officially registered delegation members will be treated in the same way and have the same rights, including, but not limited to

#### Accommodation

All teams are accommodated at IHF approved hotels of international level and according to IHF requirements. 8 double and 5 single rooms per team are foreseen (21 persons; 16 players and 5 officials).

Rooms for delegation members 22<sup>nd</sup> – 30<sup>th</sup> are guaranteed provided that the indicated deadline has been respected (see 2.9. team registration).

If a team arrives with less than 21 players, it is only entitled to receive the adequate number of rooms according to the size of the delegation.

### Food and beverages

Teams have the right to 3 meals a day: breakfast, lunch, and dinner. On matchdays the teams are also entitled to have a snack. One soft drink for lunch and dinner is free; water shall be available 24hrs a day free of charge.

### Meeting rooms

At the team hotel all teams have the right to use a meeting room equipped with DVD player, projector and flip chart. A timetable is set up by the Organising Committee in order to reserve the meeting room for the times preferred. The teams are entitled to use this meeting room free of charge provided they respect the relevant timetable.

### Team guide

Team guides are at the disposal of each team. They form the link between the participating team concerned, the organiser and the IHF and assist the teams in all matters.

### Visa

All teams have the right to be guaranteed trouble free entry into the hosting country. Visa assistance shall be provided by the Organising Committee.

### Local transportation

A heated/air-conditioned bus for local transportation for competition purposes from the day of arrival until the day of departure is available for each team.

### Medical care

At each venue a comprehensive medical service (including 24-hour emergency) is available for every accredited participant.

### Accreditation

All delegation members (for specifications refer to 2.8. team registration) shall have access to the field of play, the spectators' area and the media centre.

### Executive team representatives

The head of delegation and one further member (to be defined by the national federation in advance) will receive further treatments (e.g. access to VIP zones, invitations to official receptions, etc.).

### Olympic Qualification Tournament tickets

Each team has the right to buy tickets for Olympic Qualification Tournaments. The amount of tickets available per team and the terms and conditions will be published in the official announcement.

### VIP tickets

Further each participating federation receives a maximum of 2 VIP accreditation cards, including one ticket per accreditation to Olympic Qualification matches of its team. The participating federation has to announce the respective persons one month in advance. Unless announced in advance, they are not entitled to the named accreditation/ticket.

### Match DVD

Each team shall receive a match DVD free of charge after every match in which the corresponding team has participated. DVDs of other matches can be purchased at a price of CHF 30.-.

### Video recordings

One person per team and per venue is entitled to make video recordings for teaching and training purposes. Any person wishing to record a match must possess an accreditation card issued by the organiser. These video recordings must not be for commercial exploitation. A special authorization to make video recordings is not required; the Organising Committee however, shall issue the corresponding access authorization.

### Match statistics

Teams have the right to receive the official match statistics of each match played at Olympic Qualification tournaments in printed or electronic form.

## **2.11. Duties of the participating teams**

Teams participating at Olympic Qualification Tournaments agree

- a) to comply with the IHF Statutes and Regulations and provisions of the Olympic Charta
- b) to cooperate with the IHF and the organiser and to provide all requested data and information within the given deadline
- c) to respect the principles of fairness and fair play as defined in the IHF Statutes
- d) to comply with all competition-related decisions taken by the IHF Competition Management or any other competent body
- e) to promote handball in its best way and to avoid any inappropriate behaviour that might harm the reputation of handball in any way
- f) to be a role model and to stand for the ideological values of the handball family



Further all participating teams shall respect their event-related tasks such as

- g) announcing the requested data as published in the official announcement or in the present regulations on time (arrival, team photo, etc.)
- h) confirming that all players competing in the tournament fulfil the medical and physical conditions for participation (see 2.9.)

### **2.12. Personality rights**

All participating teams grant the IHF the right to use photos and graphic materials of players and officials. Further, names and emblems of member federations may be used for event-related purposes.

All participating teams grant the IHF the right to use any kind of material produced for or at IHF Olympic Qualification Tournaments for the promotion of IHF events and sport development projects.

### **2.13. IHF INFO**

In addition to the official announcement the IHF INFO brochure will be published prior to the event, which includes more detailed event-related information and the names and contact details of the IHF nominees in every venue.



## **ARTICLE 3**

---

### **III. Technical Section**

#### **3.1. Player eligibility**

The Player Eligibility Code shall apply. Players shall prove their citizenship by presenting a passport, which will be checked by the COC before the start of the Olympic Qualification Tournament. IHF shall check the eligibility of all players within one week after receiving the provisional lists.

The minimum age of 16 is fixed for the participation at Men's and Women's Olympic Qualification Tournaments, meaning that players eligible to participate have to turn 16 years on the day of his/her first match at the latest.

If a banned player is used, penalties and fines will be imposed. Please refer to the Regulations concerning Penalties and Fines, article 17.

### 3.2. Competition dates

Between February and two months before the start of the Olympic Games the Olympic Qualification Tournaments shall be held. The IHF-COC shall fix the exact dates of the competitions, which will be included in the IHF event calendar.

The IHF Executive Committee shall finalise and confirm the dates of the tournament before the corresponding announcement being drawn up.

### 3.3. Match scheme

At each of the three Olympic Qualification Tournaments six matches will be staged and each of the four participating teams will compete in three matches.

	Matches
Matchday 1	3-4 1-2
Matchday 2	1-3 2-4
Matchday 3	4-1 2-3

Throw-off times

The throw-off times shall be fixed by the IHF in conjunction with the organiser and the TV rights-holder. Every team must be allocated a break of at least 20 hours between the throw-off times of one match and another.

### 3.4. Match evaluation and determination of places

The matches shall be evaluated as follows:

- each match won = 2 points
- each match drawn = 1 point for each team
- each match lost = no points

Teams are ranked according to the total number of points gained.

If two or more teams have gained the same number of points after the group matches have been completed, classification is decided as follows:

- results in points between the teams concerned
- goal differences in the matches between the teams concerned
- greater number of plus goals in the matches between the teams concerned.

If the teams are still equal, a decision is made between those teams with equal number of points as follows:

- goal difference is subtracted in all matches
- greater number of plus goals in all matches.

If classification still is not possible, a draw shall decide. The IHF representative on site shall execute the draw, if possible in the presence of the ‘responsible team officials’. If the ‘responsible team official’ cannot be present, other co-workers selected by the IHF shall take part.

#### Olympic Games Qualification

The teams ranked first and second at the end of each tournament earn direct qualification to the Olympic Games.

#### **3.5. Cancellation or discontinuation of match**

If the match is cancelled or discontinued, the Competition Management shall decide on further action.

#### **3.6. Official balls**

Only balls of the IHF partner will be used at Men’s and Women’s Olympic Qualification Tournaments. All participating teams will receive training balls in advance to get familiar with the ball.

#### **3.7. Players’ uniform**

Only players’ uniforms in accordance with the IHF Equipment Regulations are allowed. The approval procedure must be followed as laid down in the Equipment Regulations. Detailed specifications for players’ uniforms including advertising rights and duties are laid down in the Equipment Regulations.

#### Implementing rules

At the Technical Meeting held prior to the start of the Olympic Qualification Tournament each delegation is obliged to show the three differently coloured sets of uniform.

In each match one team shall wear light-coloured shirts and the other team dark-coloured shirts.

For the preliminary round the colours have to be decided at the Technical Meeting before the matches. The decision of colours in each match will be taken with participation of the team representatives and the IHF Technical Delegates. In case of disagreement regarding the colours the team named first has the right to choose the colour.

The Competition Management decides the colours of the players' uniforms for all matches except for the preliminary round matches.

#### **3.7.1. Officials' clothing (officials A-F)**

Specifications about the clothing of team officials are laid down in the Equipment Regulations.

#### **3.7.2. Referees' clothing**

Specifications about the clothing of referees are laid down in the Equipment Regulations.

### **3.8. Playing halls**

IHF competitions shall exclusively be held in playing halls complying with the IHF Regulations and the respective IHF Event Manual.

### **3.9. Training sessions**

One month before the start of the Olympic Qualification Tournament the training schedule, which has been submitted by the organiser and approved by the IHF, is announced to the teams. The following specifications must be strictly adhered to.

- a) Each team must be granted the same conditions and has the right to train for at least 45 minutes every day. Furthermore all teams shall be entitled to at least one training session in the playing hall prior to its first match in the respective venue. In case training in the playing hall is not possible for extraordinary reasons, the IHF Competition Management may decide.
- b) The break between the training sessions of different teams should be 5 to 10 minutes.
- c) Training sessions may be used for training matches against other teams.
- d) The first 10 minutes of every training session in the respective main hall shall be open to the media. The teams are free to agree on complete training slots open to the media after consultation with the media representatives.
- e) Water for players will be provided during the training session. Further specifications are laid down in the IHF Bid and Event Manual (40. Training schedule).
- f) Each team must bring its own balls to the training hall. For this purpose the competition balls provided to the teams prior to the tournament and supplied by the IHF partner might be used.
- g) The Competition Management has the final decision on the training schedule.

### **3.10. Substitution area**

The IHF Substitution Area Regulations shall apply. No facilities and sport equipment (e.g. bicycles, barbells, etc.) are allowed in the substitution area for the warm-up.

### **3.11. Competition Management**

A Competition Management shall be formed, which is generally chaired by the COC Chairperson. Members are the PRC Chairperson and the CCM Chairperson. In case of absence of certain members the Executive Committee may nominate replacements.

The Competition Management is responsible for the orderly management of the event, in close cooperation with the organiser. It represents the first contact point for organisational issues. It gives advice and makes all the necessary decisions during the event, with the exception of disciplinary decisions. It is also responsible for the appointment of Officials, Technical Delegates and referees.

### **3.12. Referees / Technical Delegates / Officials**

The IHF nominees (Representatives, Officials, Delegates, Referees, etc.) are announced at the latest two months prior to the start of the Olympic Qualification Tournaments.

### **3.13. Rules of the Game**

Matches shall be played according to the Rules of the Game currently valid. The IHF has the right to approve special rules valid for Olympic Qualification Tournaments.

In general the following regulations are valid for IHF events.

#### *16 players per match*

16 players may be put in per match at Olympic Qualification Tournaments and related qualifying rounds.

#### *Half-time break*

The half-time break at the Olympic Qualification Tournaments shall be 15 minutes.

#### *Team-Time Out*

According to Rule 2:10 and Clarification 3 of the Rules of the Game each team has the right to receive a maximum of three team time-outs during regular playing time but not during overtime. No more than two team time-outs may be granted in each half of the regular playing time. Between two team time-outs of a team, the opponent must be at least once in possession of the ball. 3 green cards, bearing numbers 1, 2, and 3 respectively, are available for each team. The teams receive cards bearing numbers '1' and '2' in the first half of the game and the cards no. 2 and no. 3 in the second half provided they received no more than one team time-out in the first half. In case they received two team time-outs in the first half, they receive only green card no. 3.

Within the last 5 minutes of the regular playing time only one team time-out per team is allowed.

#### **3.14. Match Management**

One IHF Official and two IHF Technical Delegates shall form the Match Jury together with the timekeeper and scorekeeper appointed by the organiser. At least one of those two persons shall be fluent in English. The announcer shall be seated near the table.

#### **3.15. Match supervision**

The match shall be under the IHF Official's full supervision.

#### **3.16. Technical Meeting**

A Technical Meeting with the team officials of the participating delegations, the organiser and the IHF representatives shall be held at the beginning of the tournament. In this meeting, all necessary information will be provided and organisational, technical and financial issues can be settled. Furthermore the definitive registration lists will be approved and the uniform colours for the preliminary round will be determined.

Further Technical Meetings might be held if required.

#### **3.17. Doping tests**

Doping tests shall be carried out according to the IHF Anti-Doping Regulations.

#### **3.18. Scouting system**

The IHF and the organiser assure the data processing to produce all match-relevant statistics.



## **ARTICLE 4**

---

### **IV. Legal Section**

Any disputes arising during a competition shall be dealt with by the IHF appeal authorities. The procedure of raising protests and appeals and further specifications are laid down in the Legal Provisions. In addition the IHF will describe the procedures that apply for the relevant event in the corresponding official announcement.



## V. Financial Section

The participants shall bear the following costs:

### Travel expenses

Travel expenses for the entire participating delegation have to be borne by the participating national federations, unless otherwise decided and communicated by the IHF. The IHF shall fix the place of arrival and departure in close cooperation with the organiser.

### Cost of visas

Participants shall bear all costs in connection with obtaining necessary visas.

### Registration fee

Nations taking part at Olympic Qualification Tournaments shall pay the IHF a registration fee of CHF 1,000.–. The payment deadline is the same date as the registration deadline.

### Fixed deposit

All participants shall pay the IHF, at the same time as the registration fee, a deposit of CHF 10,000.– which will be taken on account or repaid. If a registering federation has the uncharged sum of CHF 10,000.– on its account with the IHF, this may be used as the fixed deposit. The federation's IHF account will be credited with the relevant sum after the tournament. If the country withdraws, the sum shall be forfeited to the benefit of the IHF.

During the Olympic Qualification Tournament the IHF has the right to freely dispose of the fixed deposit of each team and may use it to pay fees, fines or other financial obligations of the corresponding federation.

### Expenses in the host country

All expenses arising within the host country in connection with the games have to be borne by the participating teams.

### Accident and sickness insurance

Federations taking part at Olympic Qualification Tournaments are obliged to insure all delegation members, i. e. all players and all officials, against accident and sickness, at their own cost. The organiser and the IHF shall not be held liable for any accidents that occur or any sickness unless the IHF has concluded a corresponding insurance for participants of the corresponding event.

### Days of stay

When calculating the participation fee, the number of days is generally counted from 12 noon on the day of arrival to 12 noon on the day of departure, i.e. although the days of arrival and departure make up two calendar days, they represent only one fee-paying day. (Additional meals – on the day of arrival possibly breakfast, on the day of departure possibly lunch and/or supper – shall be paid for in addition.) Arrival day is generally one day prior to the first match and departure day one day after the last match of the corresponding team.

### Extra days (outside the event period)

After coordination with the organiser each team may arrive earlier or leave later provided it pays additional costs set by the organiser and announced by the IHF in the official announcement itself. The exact amount for additional days will be fixed by the organiser and will then be published in the official announcement.

### Additional participants

A team delegation may be composed of 30 persons maximum during the period of the Olympic Qualification Tournament provided it bears the costs which have been set by the organiser and announced by the IHF in the official announcement (see 2.8.). The exact amount for additional participants is fixed by the organiser and will then be published in the official announcement.



## ARTICLE 6

---

### **VI. Television, media and advertising**

#### Television, film and video rights, advertising at the playing halls

The IHF alone shall hold these rights. The corresponding agreements shall be made with the respective organiser.

The IHF shall receive the revenues from television, film and video and income from advertising in at the halls.

#### Advertising on sportswear

Rights in respect of advertising on sportswear are laid down in the Regulations on Advertising and the Equipment Regulations.



## Video recordings

After the end of the Olympic Qualification tournament the organiser shall provide the IHF with video recordings of all matches free of charge.

## Press conference

A post-match press conference will take place in general approximately 15 minutes after the end of each match in the press conference room. The head coach and a player of each team shall attend the press conference conducted in English. The IHF Media Department will inform about special requirements on site.



## ARTICLE 7

---

### VII. Awards and ceremonies

#### Pre- and post-match procedure

The procedure before and after the match will be published in the official announcement. All parties involved shall strictly adhere to these guidelines.

#### a) Player of the Match

The IHF has the right to award the most valuable player in every match of the Olympic Qualification Tournament who shall receive the Player of the Match award. The IHF-CCM (or its representatives) shall decide about the awarding of the player.

No other awards than the aforementioned shall be presented at the end of the event.



## ARTICLE 8

---

### VIII. Closing comment

Further provisions regarding organisation are stipulated in the IHF Event Manual. Should any problems arise at Men's and Women's Olympic Qualification Tournaments that are not covered by the present Regulations, the Competition Management shall decide. In case of non-observance of these Regulations, Regulations concerning Penalties and Fines (XIX) shall apply.

6.

**Super Globe**



## ARTICLE 1

---

### I. Awarding

The IHF Super Globe is an IHF competition for club teams. The IHF Council entrusts the Super Globe to a member federation that has applied to hold it. Further regulations and obligations as part of the bidding procedure are laid down in the IHF Bid and Event Manual which forms the basic principles for the preparation and staging of IHF events.



## ARTICLE 2

---

### II. Administrative Section

#### 2.1. Announcement

The IHF Head Office shall announce the Super Globe with reference to the Statutes and the Regulations for IHF Competitions. This announcement will be sent to the participating clubs and will contain, in large parts, information laid down in the Competitions section of the IHF Statutes and Regulations, but also more specific information about the event including all dates and deadlines which shall be respected.

#### 2.2. Number of participants

The number of participants at the IHF Super Globe shall be 8 teams.

#### 2.3. Compulsory and performance places

The 8 teams participating at the IHF Super Globe are composed as follows:

Organiser:	one (1)
Reigning Champion:	one (1) The reigning Champion automatically qualifies for the next IHF Super Globe
Compulsory places (5 in total):	
Africa	one (1)
Asia	one (1)
Europe	one (1)

Pan-America	one (1)
Oceania	one (1)
Wild card	one (1)*

*\*The wild card will be awarded to a team by the Executive committee.*

The 8 teams will be seeded in the performance rows according to the results of the preceding IHF Super Globe as follows:

1	Reigning Champion	Continental qualifier
2	Continental qualifier	Continental qualifier
3	Wild card	Organiser
4	Continental qualifier	Continental qualifier

The reigning champion automatically qualifies for the next Super Globe and, as a rule, is placed first in the first performance row.

#### **2.4. Qualifying for the IHF Super Globe**

The IHF owns the rights to Super Globe qualifications. As laid down in the IHF Statutes, qualifying shall be through the continents (with the exception of the organiser) according to clearly regulated performance criteria and other necessary regulations defined by the IHF. The IHF-COC confirms the final allocation of qualified teams to the performance rows as announced by the continental confederations based on performance criteria. The draw basically takes place after completion of all continental qualifying rounds.

#### **2.5. Qualifying dates**

As a matter of principle, continental qualifying rounds for the IHF Super Globe must be completed no later than 2 months before the start of the event.

#### **2.6. Registration**

Upon completion of qualifications the continental confederations are obliged to inform the IHF Head Office within one (1) week about the ranking, the teams qualified and the substitute nations. The IHF will then contact the clubs concerned directly.

## **2.7. Draw**

The draw, held by the IHF (COC), shall be in compliance with the performance criteria. The organiser shall have a free choice of its preliminary round group within its performance row that is drawn last.

Technical and organisational details about the draw event are laid down in the IHF Bid and Event Manual.

## **2.8. Non-appearance**

If the team that has qualified for the IHF Super Globe does not take part, the first substitute club of the continent in question shall take the place. If the first substitute club does not take part, the IHF will decide.

## **2.9. Team registration**

Delegations may consist of up to 30 persons. The participating federation must bear the costs of delegation members ranked 22<sup>nd</sup> to 30<sup>th</sup> in the list. These delegation members have the same rights and duties (usage of organised transport, accreditation, meals, etc.) as the first 21 ranked delegation members, in case they have been officially registered and the conditions and requirements outlined by the organiser have been respected. In case the participating federation fails to pay the fixed fee for additional participants, these additional participants are not entitled to use the services included in the rights of participating teams (accommodation, meals, transportation, medical care, etc.), laid down in 2.11. of the present document.

Players and the remainder as officials (stating their function) shall be registered as follows:

- provisionally: one month before the start of the IHF Super Globe at the latest (28 players at most) to the IHF Head Office
- definitively: one hour before the Technical Meeting to the responsible IHF representative (16 players taken from the provisional list). The registration must be executed with help of the relevant IHF form (see Annex 1).

*\*Players who are not on the provisional list, but have made an unlimited transfer to a club participating on the Super Globe prior to the event, are eligible to be included in the definite registration list.*

The registration, on the relevant IHF form, must include.

- a) officials (who should not be changed during the entire competition)\* with the following details: surname, first name, date of birth, nationality, gender, function within the delegation and indication of the officials (by use of letters A, B, C, D, E, F);  
the following functions must be used: head coach, assistant coach, physiotherapist, doctor, team official  
*\*In exceptional cases the IHF Competition Management may allow the replacement of up to two officials during competition on request of the NF concerned (e.g. in case of serious health issues).*
- b) players with the following details: players' number, surname, first name, club, date of birth, height, weight, throwing hand, main position, number of international games, number of goals scored in international matches
- c) colour of players' uniforms (see Equipment Regulations for detailed specifications)

In case of submitting incorrect or incomplete forms fines may be imposed.

#### Provisional registration

Even if a team has registered less than 28 players, the provisional list is final and cannot be changed once the deadline has expired.

#### Player replacement

During the tournament each team may replace up to three players (against three players indicated in the provisional list) at any time (e.g. each team may put in three new players or may put in a player who has already been replaced once). Players may be replaced against players indicated in the provisional delegation list ('list of 28') only.

In case a suspended player is replaced by another player, the new player is only eligible to play after the suspension has lapsed.

If a team has registered less than 16 players, it may register one additional player during the tournament.

#### *Procedure for late registration or substitution of one or several players.*

New players must be orally registered to the Competition Management or the responsible IHF delegate in the corresponding venue at 9.00 am on the respective matchday at the latest. A written registration and a proof of citizenship (passport, etc.) shall follow one hour before the match at the latest. The official IHF form must be used. (see Annex 2)

## **2.10. Formal confirmation of participation**

All qualified clubs have to confirm their participation at the IHF Super Globe in writing by use of the corresponding form attached to the official announcement. Further the participating nations are held to confirm that all players competing in the tournament fulfil the medical and physical conditions for participation. For that purpose the players to compete at the IHF Super Globe shall undergo a medical exam in advance in order to receive a certificate of health. By use of the corresponding form the federations concerned shall confirm its players' health status saying that they have received such certificate and fulfil the medical and physical conditions to compete at the tournament.

## **2.11. Rights of participating teams**

All officially registered delegation members will be treated in the same way and have the same rights, including, but not limited to

### Accommodation

All teams are accommodated at IHF approved hotels of international level and according to IHF requirements. 8 double and 5 single rooms per team are foreseen (21 persons; 16 players and 5 officials).

Rooms for delegation members 22<sup>nd</sup> – 30<sup>th</sup> are guaranteed provided that the indicated deadline has been respected (see 2.9. team registration). If a team arrives with less than 21 players, it is only entitled to receive the adequate number of rooms according to the size of the delegation.

### Food and beverages

Teams have the right to 3 meals a day: breakfast, lunch, and dinner. On matchdays the teams are also entitled to have a snack. One soft drink for lunch and dinner is free; water shall be available 24hrs a day free of charge.

### Meeting rooms

At the team hotel all teams have the right to use a meeting room equipped with DVD player, projector and flip chart. A timetable is set up by the Organising Committee in order to reserve the meeting room for the times preferred. The teams are entitled to use this meeting room free of charge provided they respect the relevant timetable.

### Team guide

Team guides are at the disposal of each team. They form the link between the participating team concerned, the organiser and the IHF and assist the teams in all matters.

#### Visa

All teams have the right to be guaranteed trouble free entry into the hosting country. Visa assistance shall be provided by the Organising Committee.

#### Local transportation

A heated/air-conditioned bus for local transportation for competition purposes from the day of arrival until the day of departure is available for each team.

#### Medical care

At each venue a comprehensive medical service (including 24-hour emergency) is available for every accredited participant.

#### Accreditation

All delegation members (for specifications refer to 2.9 team registration) shall have access to the field of play, the spectators' area and the media centre.

#### Executive team representatives

The head of delegation and one further member (to be defined by the club in advance) will receive further treatments (e.g. access to VIP zones, invitations to official receptions, etc.).

#### Super Globe tickets

Each team has the right to buy Super Globe tickets. The amount of tickets available per team and the terms and conditions will be published in the official announcement.

#### VIP tickets

Further each participating federation receives a maximum of 2 VIP accreditation cards, including one ticket per accreditation to IHF Super Globe matches of its team. The participating federation has to announce the respective persons one month in advance. Unless announced in advance, they are not entitled to the named accreditation/ticket.

#### Match DVD

Each team shall receive a match DVD free of charge after every match in which the corresponding team has participated. DVDs of other matches can be purchased at a price of CHF 30.-.

#### Video recordings

One person per team and per venue is entitled to make video recordings for teaching and training purposes. Any person wishing to record a match must possess an accreditation card issued by the organiser. These video recordings must not be for commercial exploitation. A



special authorization to make video recordings is not required; the Organising Committee however, shall issue the corresponding access authorization.

#### Match statistics

Teams have the right to receive the official match statistics of each tournament match in printed or electronic form.

### **2.12. Duties of the participating teams**

Teams participating in the IHF Super Globe agree

- a) to comply with the IHF Statutes and Regulations
- b) to cooperate with the IHF and the organiser and to provide all requested data and information within the given deadline
- c) to respect the principles of fairness and fair play as defined in the IHF Statutes
- d) to comply with all competition-related decisions taken by the IHF Competition Management or any other competent body
- e) to promote handball in its best way and to avoid any inappropriate behaviour that might harm the reputation of handball in any way
- f) to be a role model and to stand for the ideological values of the handball family

Further all participating teams shall respect their event-related tasks such as

- g) announcing the requested data as published in the official announcement or in the present regulations on time (arrival, team photo, etc.)
- h) confirming that all players competing in the tournament fulfil the medical and physical conditions for participation (see 2.10).

### **2.13. Personality rights**

All participating teams grant the IHF the right to use photos and graphic materials of players and officials. Further, names and emblems of member federations may be used for event-related purposes.

All participating teams grant the IHF the right to use any kind of material produced for or at the IHF Super Globe for the promotion of IHF events and sport development projects.

### **2.14. IHF INFO**

In addition to the official announcement the IHF INFO brochure will be published prior to the event, which includes more detailed event-related information.



### III. Technical Section

#### 3.1. Player eligibility

The Player Eligibility Code shall apply. Players competing in the IHF Super Globe shall meet the following provisions:

- a) The player has to be registered, as an amateur or a professional player, with the participating club's member federation.
- b) If registered as a professional player, a written employment contract, binding the professional player to his/her club, must exist.
- c) The participating club's member federation shall submit a confirmation to the IHF that the player indicated in the provisional team list of the participating club concerned is eligible to play in the respective country and that all provisions for an orderly transfer of the player concerned have been fulfilled. The participating club shall submit the named confirmation together with the provisional team list.
- d) A maximum of three (3) so called "short-term transfers" (loan or unlimited transfers) per team are permitted.
- e) The Minimum duration of contracts of "short-term transfers" (loan or unlimited) are two months.\*
- f) Unlimited number of transfers (loan or unlimited) whose contract duration is longer than two months are allowed.\*

*\* The beginning of the validity of the contract is determined by the date in the signed copy of the contract and not by the date of issuing the International Transfer Certificate.*

If a banned player is used, penalties and fines will be imposed. Please refer to the Regulations concerning Penalties and Fines, article 17.

#### 3.2. Competition dates

The IHF-COC shall fix the exact dates of the competition in accordance with the organiser. The IHF Executive Committee shall finalise and confirm the dates of the tournament before the corresponding announcement being drawn up.

#### 3.3. Match scheme

The tournament is played in two groups of four, followed by semi-finals, placement-round, placement matches and finals.

### **Preliminary Round (6 matches)**

(Groups A and B)

PR 1 1-3, 2-4

PR 2 3-2, 4-1

PR 3 1-2, 3-4

*The teams ranked 1<sup>st</sup> and 2<sup>nd</sup> of each preliminary round group advance to the semi-finals; the teams ranked 3<sup>rd</sup> and 4<sup>th</sup> will compete in the placement round.*

### **Semi-Finals (4 matches)**

1.A - 2.B / SF 1

2.A - 1.B / SF 2

### **Placement round (2 matches)**

3.A - 4.B / PR 1

4.A - 3.B / PR 2

### **Placement matches (2 matches)**

WPM1 - WPM2 / (5/6)

LPM2 - LPM2 / (7/8)

### **Finals (2 matches)**

WSF1 - WSF2

LSF2 - LSF 2

### **Day by Day •**

0- Arrival of all teams

1- Preliminary Round (4 matches)

2- Preliminary Round (4 matches)

3- Preliminary Round (4 matches)

4- Rest day

5- Semi-Finals / Placement round (4 matches)

6- Placement matches / Finals (4 matches)

7- Departure

*\*This is a general set-up. On request of media, TV or other international bodies, the IHF-COC may decide an alternative schedule, following the above-mentioned principles.*

Throw-off times

The throw-off times shall be fixed by the IHF in conjunction with the organiser and the TV rights-holder. Every team must be allocated a break of at least 20 hours between the throw-off times of one match and another.

### **3.4. Match evaluation and determination of places**

#### **3.4.1. Preliminary round**

The preliminary round is played in groups. The matches shall be evaluated as follows:

- each match won = 2 points
- each match drawn = 1 point for each team
- each match lost = no points

Teams are ranked according to the total number of points gained.

If two or more teams have gained the same number of points after the group matches have been completed, classification is decided as follows:

- results in points between the teams concerned
- goal differences in the matches between the teams concerned
- greater number of plus goals in the matches between the teams concerned.

If the teams are still equal, a decision is made between those teams with equal number of points as follows:

- goal difference is subtracted in all matches
- greater number of plus goals in all matches.

If classification still is not possible, a draw shall decide. The IHF representative on site shall execute the draw, if possible in the presence of the ‘responsible team officials’. If the ‘responsible team official’ cannot be present, other co-workers selected by the IHF shall take part.

#### **3.4.2. Placement matches, semi-finals and finals**

After completion of the preliminary round, the placement matches, semi-finals and finals shall be played in accordance with the knock-out system.

Overtime is played, following a 5-minute break, if a game is tied at the end of the regular playing time and a winner has to be determined. The overtime period consists of 2 halves of 5 minutes, with a 1-minute half-time break.

If the game is again tied after a first overtime period, a second period is played after a 5-minute break. This overtime period also has 2 halves of 5 minutes, with a 1-minute half-time break.

Should the match still not be decided after the second overtime period, it is decided with 7m penalty throws in accordance with Rule 2.2 of the Rules of the Game.

The IHF COC has the right to decide that certain matches will be executed with direct 7m penalty throws in accordance with Rule 2.2 of the Rules of the Game. If this rule applies, the decision will be published in the official announcement or together with the match schedule.

Placement matches

In case of a draw at the end of the regular playing time of the placement round and placement matches the match will be decided with 7m penalty throws in accordance with Rule 2.2 of the Rules of the Game.

### **3.5. Cancellation or discontinuation of match**

If the match is cancelled or discontinued, the Competition Management shall decide on further action.

### **3.6. Official balls**

Only balls of the IHF partner will be used at IHF Super Globe.

### **3.7. Players' uniform**

Only players' uniforms in accordance with the IHF Equipment Regulations are allowed. The approval procedure must be followed as laid down in the Equipment Regulations. Detailed specifications for players' uniforms including advertising rights and duties are laid down in the Equipment Regulations.

#### Implementing rules

At the Technical Meeting held prior to the start of the IHF Super Globe each delegation is obliged to show the three differently coloured sets of uniform.

In each match one team shall wear light-coloured shirts and the other team dark-coloured shirts.

For the preliminary round the colours have to be decided at the Technical Meeting before the matches. The decision of colours in each match will be taken with participation of the team representatives and the IHF Technical Delegates. In case of disagreement regarding the colours the team named first has the right to choose the colour.

#### **3.7.1. Officials' clothing (officials A-F)**

Specifications about the clothing of team officials are laid down in the Equipment Regulations.

#### **3.7.2. Referees' clothing**

Specifications about the clothing of referees are laid down in the Equipment Regulations.

### **3.8. Playing halls**

IHF competitions shall exclusively be held in playing halls complying with the IHF Regulations and the respective IHF Bid and Event Manual.

### **3.9. Training sessions**

One month before the start of the tournament the training schedule, which has been submitted by the organiser and approved by the IHF, is announced to the teams. The following specifications must be strictly adhered to:

- a) Each team must be granted the same conditions and has the right to train for at least 45 minutes every day. Furthermore all teams shall be entitled to at least one training session in the playing hall prior to its first match in the respective venue. In case training in the playing hall is not possible for extraordinary reasons, the IHF Competition Management may decide.
- b) The break between the training sessions of different teams should be 5 to 10 minutes.
- c) Training sessions may be used for training matches against other teams.
- d) The first 10 minutes of every training session in the respective main hall shall be open to the media. The teams are free to agree on complete training slots open to the media after consultation with the media representatives.
- e) Water for players will be provided during the training session. Further specifications are laid down in the IHF Bid and Event Manual (40. Training schedule).
- f) Each team must bring its own balls to the training hall. For this purpose the competition balls provided to the teams prior to the tournament and supplied by the IHF partner might be used.
- g) The Competition Management has the final decision on the training schedule.

### **3.10. Substitution area**

The IHF Substitution Area Regulations shall apply. No facilities and sport equipment (e.g. bicycles, barbells, etc.) are allowed in the substitution area for the warm-up.

### **3.11. Competition Management**

A Competition Management shall be formed, which is generally chaired by the COC Chairperson. Members are the PRC Chairperson and the CCM Chairperson. In case of absence of certain members the Executive Committee may nominate replacements.

The Competition Management is responsible for the orderly management of the event, in close cooperation with the organiser. It represents the first contact point for organisational issues. It gives advice and makes all the necessary decisions during the event, with the exception of disciplinary decisions. It is also responsible for the appointment of Officials, Technical Delegates and referees.

In the venues where the Competition Management is not present the body delegates the aforementioned tasks to the COC delegate (to be announced in IHF INFO, see 2.14.), who is supported by a member of the Head Office.

### **3.12. Referees / Technical Delegates / Officials**

The IHF nominees (Representatives, Officials, Delegates, Referees, etc.) are announced at the latest one month prior to the start of the tournament.

### **3.13. Rules of the Game**

Matches shall be played according to the Rules of the Game currently valid.

In general the following regulations are valid for IHF events.

#### *16 players per match*

16 players may be put in per match at the IHF Super Globe and related qualifying rounds.

#### *Half-time break*

The half-time break at the IHF Super Globe shall be 15 minutes.

#### *Team-Time Out*

According to Rule 2:10 and Clarification 3 of the Rules of the Game each team has the right to receive a maximum of three team time-outs during regular playing time but not during overtime. No more than two team time-outs may be granted in each half of the regular playing time. Between two team time-outs of a team, the opponent must be at least once in possession

of the ball. 3 green cards, bearing numbers 1, 2, and 3 respectively, are available for each team. The teams receive cards bearing numbers '1' and '2' in the first half of the game and the cards no. 2 and no. 3 in the second half provided they received no more than one team time-out in the first half. In case they received two team time-outs in the first half, they receive only green card no. 3.

Within the last 5 minutes of the regular playing time only one team time-out per team is allowed.

#### **3.14. Match Management**

One IHF Official and two IHF Technical Delegates shall form the Match Management together with the timekeeper and scorekeeper appointed by the organiser. At least one of those two persons shall be fluent in English. The announcer shall be seated near the table.

#### **3.15. Match supervision**

The match shall be under the IHF Official's full supervision.

#### **3.16. Technical Meeting**

A Technical Meeting with the team officials of the participating delegations, the organiser and the IHF representatives shall be held at the beginning of the tournament. In this meeting, all necessary information will be provided and organisational, technical and financial issues can be settled. Furthermore the definitive registration lists will be approved and the uniform colours for the preliminary round will be determined.

Further Technical Meetings might be held if required.

#### **3.17. Doping tests**

Doping tests shall be carried out according to the IHF Anti-Doping Regulations.

#### **3.18. Scouting system**

The IHF and the organiser assure the data processing to produce all match-relevant statistics.

#### **3.19. Prize money**

The teams ranked first to third will receive prize money. Details hereto are specified in the corresponding official announcement.





## ARTICLE 4

---

### IV. Legal Section

Any disputes arising during a competition shall be dealt with by the IHF appeal authorities. The procedure of raising protests and appeals and further specifications are laid down in the Legal Provisions. In addition the IHF will describe the procedures that apply for the relevant event in the corresponding official announcement.



## ARTICLE 5

---

### V. Financial Section

#### 5.1. Costs to be borne by the organiser.

Travel expenses

The organiser will cover the travel expenses for the participating teams (for 21 persons in economy class) provided the participating teams follow the instructions and submit the required information within the deadlines indicated in the official announcement. In case of non-compliance with the instructions or with meeting the deadlines, travel expenses might have to be charged to the corresponding team.

Board and lodging

Accommodation expenses for 21 persons per delegation are paid by the organiser. The costs for additional participants, however, have to be borne by the participating teams.

Visa costs of the delegations

Possible visa costs of the delegations are borne by the organiser provided the participating teams submit the required documents within the deadline indicated in the official announcement to the organiser. If the deadline is not met, the claim of receiving the visa free of charge might expire.

#### 5.2. Costs to be borne by the participating clubs.

Accident and sickness insurance

All teams participating at the IHF Super Globe are obliged to insure all delegation members, i.e. all players and all officials, against accident and sickness, at their own cost. The organiser and the IHF shall not be held liable for any accidents that occur or any sickness.

#### Extra days

After coordination with the organiser each team may arrive earlier or leave later provided it pays additional costs set by the organiser and announced by the IHF in the official announcement itself. The exact amount for additional days will be fixed by the organiser and will then be published in the official announcement.

#### Additional participants

A team delegation may be composed of 30 persons maximum during the IHF Super Globe period provided it pays itself the costs which have been set by the organiser and announced by the IHF in the official announcement (see 2.9.). The exact amount for additional participants is fixed by the organiser and will then be published in the official announcement.



## ARTICLE 6

---

### **VI. Television, media and advertising**

#### Television, film and video rights, advertising at the playing halls

The IHF alone shall hold these rights. The corresponding agreements shall be made with the respective organiser.

The IHF shall receive the revenues from television, film and video and income from advertising at the halls.

#### Advertising on sportswear

Rights in respect of advertising on sportswear are laid down in the Regulations on Advertising and the Equipment Regulations.

#### Video recordings

After the end of the tournament the organiser shall provide the IHF with video recordings of all matches free of charge.

#### Press conference

A post-match press conference will take place in general approximately 15 minutes after the end of each match in the press conference room. The head coach and a player of each team shall attend the press conference conducted in English. The IHF Media Department will inform about special requirements on site.



## VII. Awards and ceremonies

### Pre- and post-match procedure

The procedure before and after the match will be published in the official announcement. All parties involved shall strictly adhere to these guidelines.

### Opening and closing ceremony

The opening and closing ceremonies shall be of reasonable and appropriate proportions. Details are contained in the List of Duties for Official IHF Competitions and the IHF Bid and Event Manual.

### Winners (places 1 – 3)

Medals and certificates shall be awarded (to a maximum of 25 persons) to the three top teams as follows:

- 1<sup>st</sup> place and champion (gold)
- 2<sup>nd</sup> place (silver)
- 3<sup>rd</sup> place (bronze)

On the podium a total of 21 persons are allowed (players who have participated in tournament and team officials A-E).

Additionally a trophy will be awarded to the IHF Super Globe champions.

All other teams shall receive a souvenir medal.

### Head Office

One set of medals and certificates shall be preserved in the IHF Head Office archives.

At the IHF Super Globe, the following official awards shall be presented:

#### **a) Player of the Match**

The IHF has the right to award the most valuable player in every IHF Super Globe match who shall receive the Player of the Match award. The IHF-CCM (or its representatives) shall decide about the awarding of the player.

**b) All-Star Team**

The IHF All-Star Team will be designated by the IHF-CCM experts attending the IHF Super Globe and will be announced after the final.

**c) Top Scorer**

The player who has scored the largest number of goals during the entire tournament shall receive the IHF Top Scorer award. If two or more players have scored the same number of goals, the number of assists will be decisive.

**d) Most Valuable Player (MVP)**

The best player of the tournament shall receive the MVP award. The MVP will be designated by the IHF-CCM experts attending the IHF Super Globe.

No other awards than the aforementioned shall be presented at the IHF Super Globe.



**ARTICLE 8**

---

**VIII. Closing comment**

Further provisions regarding organisation are stipulated in the IHF Bid and Event Manual. Should any problems arise at the IHF Super Globe that are not covered by the present Regulations, the Competition Management shall decide. In case of non-observance of these Regulations, Regulations concerning Penalties and Fines (XIX) shall apply.

**7.**

## **Equipment Regulations**

## Table of contents

### **1. Basic principles**

### **2. Players' uniforms**

- 2.1. Colours
- 2.2. Players' numbers
- 2.3. Players' names
- 2.4. Stars to represent World Championship titles won
- 2.5. Approval procedure
- 2.6. Change of players' uniforms
- 2.7. Players' clothing during official presentation on the field of play
- 2.8. Identification of federation (emblem, national flag or name of the country) displayed on the shirt
- 2.9. Team officials' clothing
- 2.10. Disciplinary measures

### **3. Advertising on players' uniforms**

- 3.1. Manufacturer identification
- 3.2. Advertising space
- 3.3. Rights to advertising space at IHF competitions
- 3.4. Approval procedure
- 3.5. Disciplinary measures

### **4. Referees' clothing**

- 4.1. Advertising on referees' and officials' clothing



## ARTICLE 1

---

### I. Basic Principles

The IHF Equipment Regulations apply to all matches organised under the auspices of the International Handball Federation (IHF), governing the authorisation of uniforms used by players and officials of the teams representing the member federations and clothing worn by referees. Also sponsor advertising is subject to the present Equipment Regulations.

Attention is drawn to the fact that the uniform requirements may differ between the categories of IHF competitions.

The member federations shall be held liable for the correct implementation of the present Equipment Regulations of its players, coaches and officials.

The outlined provisions and corresponding illustrations also present guidelines for member federations and manufacturers in identifying and applying the different elements on sports equipment for IHF competitions.

A global and consistent equipment policy will serve for the benefit of all parties involved.

For the sake of simplicity, these regulations generally use the male form of words with respect to players, officials, referees and other persons.



## ARTICLE 2

---

### II. Players' uniforms

All the court players of a handball team must wear identical uniforms\*. The combinations of colours and design for the two teams must be clearly distinguishable from each other.

*\*players' uniforms include shirt, short (+ long-sleeve shirts worn under the official player's shirt and cycling pants, if in use, that must be the same colour as the shirt/short's colour; alternatively long-sleeves and cycling pants of another colour are permitted provided that all players wearing such shirt/pant wear the same colour) or goalkeeper pants, socks*

The players must wear sports shoes.

It is not permitted to wear objects that could be dangerous to the players. This includes, for instance, head protection, face masks, bracelets, watches, rings, visible piercing, necklaces or chains, earrings, glasses without restraining bands or with solid frames, or any other objects which could be dangerous (Rules of the Game 17.3).

Flat rings, small earrings and visible piercing may be allowed, as long as they are taped over in such a way that they are no longer deemed dangerous to other players. Headbands are allowed, as long as they are made of soft, elastic material.

Players who do not meet this requirement will not be allowed to take part until they have corrected the problem.

## **2.1. Colours**

Each team must possess **two** differently coloured sets of players' uniforms.

- a) one set of light-coloured shirts and one set of light-coloured shorts
- b) one set of dark-coloured shirts and one set of dark-coloured shorts
- c) **Three** differently coloured shirts for the goalkeeper.

At Men's and Women's World Championships all participants must bring **three** different sets of players' uniforms that meet the above-mentioned criteria.

One colour should very clearly cover the major part of the shirt.

All players used in the goalkeeper position on a team must wear the same colour, a colour that distinguishes them from the court players of both teams and the goalkeeper(s) of the opposing team.

All goalkeepers of one team must have the same shirt colours. This applies also to a court player temporarily acting as a goalkeeper.

The players' numbers shall be in a different colour from the main colour.

In each match one team shall wear light-coloured shirts and the other team dark-coloured shirts.



The uniform sets (named 1<sup>st</sup> and 2<sup>nd</sup> (and 3<sup>rd</sup> in case of Men's and Women's WChs) in order of preference) of the teams shall appear on the team list.

At the initial Technical Meeting of the IHF competition, each delegation is obliged to show the two (three in case of Men's and Women's WChs) (three for the goalkeepers) differently coloured sets of uniform.

For the preliminary round the colours have to be decided at the initial Technical Meeting. The decision of colours in each match will be taken with participation of the team representatives and the IHF delegates. In case of disagreement regarding the colours the team named first has the right to choose the colour.

The colours of players' uniforms for the matches following the preliminary round shall be fixed by the Competition Management.

## **2.2. Players' numbers**

Players must wear clearly legible numbers, the figures being placed at least 20cm high on the back and at least 10cm high on their chest. The numbers shall be in a different colour from the main colour. Numbers between 1 and 99 shall be used. The colour of the team official clothing must be different from the main colour of the opposing team.

'Temporary' goalkeepers must either have a goalkeeper shirt with the number that they normally have as court player, or they must put on a shirt in the colour of its teams' goalkeeper shirt, with holes giving a view of the number on the regular shirt. If they put a shirt, it must be the same colour and type as the colour and type of the goalkeeper shirt. No tolerance will be accepted.



During the entire IHF competition, each player must wear the same number, regardless of his/her position (goalkeeper or court player).



### 2.3. Players' names

At all IHF events (Men's and Women's Senior, Men's and Women's Junior Men's and Women's Youth World Championships and the Super Globe) and as well at Olympic Games the player's surname or popular name, that is identical to that indicated in the team list, must be displayed, in clearly legible 7cm high (minimum) capital letters, above the player's number on the back of the shirt. The names must be written in Roman letters. The teams are responsible for the application of the names.



#### **2.4. Stars to represent World Championship titles won**

A five-pointed star shall be placed on the shirt front of the players, if possible, above the federation's logo, to prove that their country had won a World Championship title in the respective WCh category. Each star placed on the shirt shall represent a World Championship title won.

*Example.*



#### **2.5. Approval procedure**

The players' uniforms shall be presented to the IHF in good time for examination. The teams participating in an IHF competition must forward a sample or coloured photos of the uniforms they want to use in a certain competition to the IHF Head Office no later than two months prior to the first matchday. The examination of the uniforms will be carried out by the Head Office. The uniforms shall be definitely approved at the Technical Meeting held prior to the competition.

The nations are obliged to bring with them only such approved uniforms for the tournament concerned.

The nations are obliged to wear the uniforms approved for the match in question.

Before the start of the match the IHF official shall make sure that the teams on the court wear the uniforms approved for the match in question.

#### **2.6. Change of players' uniform**

If the IHF official considers that the two teams' uniforms might cause confusion, the team named second in the match schedule must change its uniform in order that there is good contrast. Uniform might also prove unsuitable for TV broadcast. Therefore both teams have to bring two (three in case of Men's or Women's World Championships) sets to each match.

In all other cases the Competition Management or the official on site shall decide on the change of players' uniform.

### **2.7. Players' clothing during official presentation on the field of play**

During the official presentation prior to the matches, uniform clothing must be consistently worn by all players of a team (all players wearing tracksuits or all players in players' clothing or a combined solution is possible).

### **2.8. Identification of federation (emblem, national flag or name of the country) displayed on the shirt**

Federations shall display the federation's emblem or the national flag at chest level on the front of the shirt. Federations are entitled to place the name of the country (in Latin letters in national language or in English) on the back of the shirt below the player's number in the event that the federations are not using their right of placing advertising in this area.



### **2.9. Team officials' clothing**

Team officials entered in the match report and thus allowed to be in the substitution area must wear identical sportswear or civilian clothing which distinguishes them from the players' uniforms and training clothing. Colours which may cause confusion with the court players of the opposing team are not allowed (see Substitution Area Regulations 3).

### **2.10. Disciplinary measures**

If a member federation violates the aforementioned provisions, the IHF will pronounce sanctions or take measures in accordance with Article 14 of the IHF Regulations concerning Penalties and Fines.



### **III. Advertising on players' uniforms**

General provisions and instructions on advertising on sportswear are laid down in the IHF Regulations for Advertising on Sportswear.

Advertising may be placed on the sportswear worn by players during a match and on the sportswear and tracksuits worn by players and team officials in the places where IHF competitions are held.

The IHF itself has the right to advertise or place advertising at official IHF competitions referred to under basic principles of the Regulations for IHF Competitions.

Preference should be given to the advertising of a general sponsor of the IHF. The financial participation of the teams and clubs concerned is governed by the IHF Financial Regulations.

Advertising contracts made by national teams and club teams, which affect the priority right of the IHF particularly in the placing of advertising on sportswear, are invalid.

The use of company and product names, trademarks and classes of goods is permitted, provided that they do not offend common decency. The advertising may not be of a political, confessional, racist or ideological nature.

National regulations (bans on advertising for tobacco, alcohol, drugs, etc.) must be observed.

The use of fluorescent colours is not permitted. This ban applies not only to advertising but also to the material of the sportswear and tracksuits in general.

Advertising on team officials' clothing is not limited by the International Handball Federation. The member federations shall make sure that the aforementioned general guidelines are met.

#### **3.1. Manufacturer identification**

The brands and labels of origin of sports manufacturers are not regarded as advertising if they do not exceed 20cm<sup>2</sup> in area.

The manufacturer may send samples of its forms of identification, along with a written description, to the IHF Head Office for inspection.

### 3.2. Advertising space

Nothing but the following is recognised as advertising space:

- (1) lower part of the shirt front:  
max two different advertising spaces with a maximum dimension of 30cm wide and 20cm high
- (2) back of the shirt below the players' number:  
max two different advertising spaces with a maximum dimension of 30cm wide and 20cm high
- (3) upper part of the shirt front: one advertising space each below the collarbone with a maximum dimension of 5cm high and 10cm wide each
- (4) outer side of the sleeves: maximum dimension of 15cm high, 10cm wide
- (5) Sides of the shirt with a maximum dimension of 10cm wide and 20cm high

The height of the individual characters must not exceed 10cm.

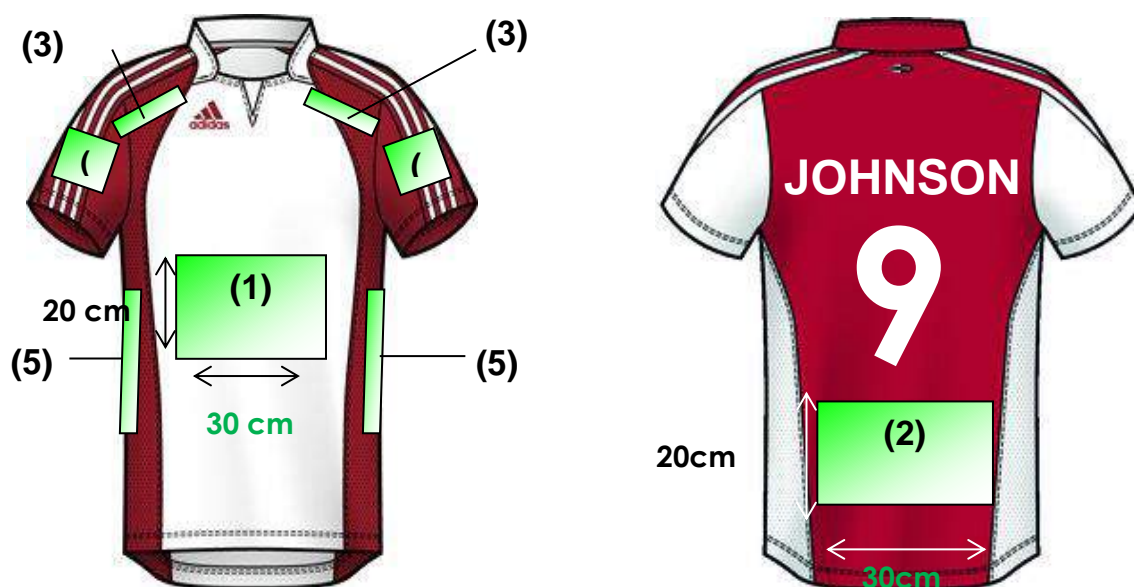

- (6) one front leg of shorts/goalkeeper pants: max two different advertising spaces with a maximum dimension of 18cm wide and 12cm high



- (7) back of shorts/goalkeeper pants: max two different advertising spaces with a maximum dimension of 25cm wide and 12cm high

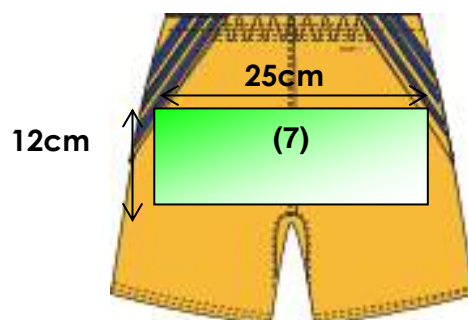

The legibility of the players' numbers on the shirt must not be affected by advertising.

Players who wear sportswear which does not conform to the regulations shall not be permitted to play.

*It applies to court players and goalkeepers. Generally speaking it is allowed to have different advertising partners for the same space on sportswear during the competition.*

### **3.3. Rights to advertising space at IHF competitions**

- The outer side of sleeves (4) is reserved exclusively for IHF advertising (without financial participation by the IHF member federations). The IHF reserves the right to place advertising or to advertise special IHF campaigns (e.g. by placing the event logo, handball at school logo, etc. in that field.)
- All other areas (as previously defined) are reserved exclusively for the advertising of IHF member federations (with no financial participation by the IHF). An individual advertiser may not request the exclusive right to advertise in a specific field. The same applies to the clothing worn by team officials.

Captain's armband, wristband, headbands, support bandages, splints must be free of advertising. Manufacturer identification is allowed.

### **3.4. Approval procedure**

As part of the examination of players' uniforms, the teams forwarding photos of uniforms shall also indicate advertising spaces they want to use or, if possible, forward uniforms including advertising to avoid non-compliance with the present regulations at an early stage.

The IHF official and the IHF technical delegates present on site shall make sure that the teams on the court wear the uniforms approved for the match in question.

The uniforms shall be definitely approved at the Technical Meeting held prior to the competition.

### **3.5. Disciplinary measures**

Non-compliance with these regulations at IHF competitions is dealt with by the Competition Management and the legal bodies of the IHF, respectively. The relevant regulations and directives of the IHF apply.



## **ARTICLE 4**

---

### **IV. Referees' clothing**

The referees must wear a shirt colour that clearly differs the players' shirts and the goalkeepers' shirts. The colour of the referee shirts to be used in the match shall be fixed in the Technical Meeting or respectively in the context of the choice of uniform colours.

IHF officials and delegates appointed for the match at IHF competitions must wear identical clothing.

#### **4.1. Advertising on referees' and officials' clothing**

Advertising is permitted on sportswear and tracksuits used by IHF referees, officials and technical delegates in the places where competitions are held. The type of advertising must be in compliance with the IHF Regulations on Advertising on Sportswear (XVII).

Advertising on referees' clothing and IHF officials' clothing is reserved for the IHF (with no financial participation by the member federations). An individual advertiser may not request the exclusive right to place advertising in a specific field.